

# HP Archive

This vintage Hewlett Packard document was  
preserved and distributed by

**[www. hparchive.com](http://www.hparchive.com)**

Please visit us on the web !

On-line curator: Tony Gerbic

# 240A SWEEP SIGNAL GENERATOR

OPERATING AND SERVICE MANUAL



[WWW.HPARCHIVE.COM](http://WWW.HPARCHIVE.COM)  
For Free Distribution Only

## CERTIFICATION

*The Hewlett-Packard Company certifies that this instrument was thoroughly tested and inspected and found to meet its published specifications when it was shipped from the factory. The Hewlett-Packard Company further certifies that its calibration measurements are traceable to the U.S. National Bureau of Standards to the extent allowed by the Bureau's calibration facility.*

## WARRANTY AND ASSISTANCE

All Hewlett-Packard products are warranted against defects in materials and workmanship. This warranty applies for one year from the date of delivery, or, in the case of certain major components listed in the operating manual, for the specified period. We will repair or replace products which prove to be defective during the warranty period. No other warranty is expressed or implied. We are not liable for consequential damages.

For any assistance contact your nearest Hewlett-Packard Sales and Service Office. Addresses are provided at the back of this manual.



OPERATING AND SERVICE MANUAL

MODEL 240A

## SWEEP SIGNAL GENERATOR

The 240A was in manufacture prior to the acquisition of Boonton Radio Company by the Hewlett-Packard Company in 1959. The front panel engraving continues to identify the original manufacturer of this instrument.

[WWW.HPARCHIVE.COM](http://WWW.HPARCHIVE.COM)  
For Free Distribution Only

Copyright

Hewlett-Packard Company

1965

Green Pond Road

Rockaway, New Jersey, U. S. A.

Printed: DEC 1965

## TABLE OF CONTENTS

Section	Page	Section	Page
I GENERAL . . . . .	1-1	4-28. Buffer Amplifier . . . . .	4-3
1-1. Introduction . . . . .	1-1	4-30. Amplitude Modulator . . . . .	4-3
1-4. Supplied Accessory 501B . . . . .	1-1	4-32. Output Attenuator . . . . .	4-3
II INSTALLATION . . . . .	2-1	4-36. Sweep Generator . . . . .	4-4
2-1. Introduction . . . . .	2-1	4-40. Shaping Circuits . . . . .	4-4
2-3. Unpacking and Inspection . . . . .	2-1	4-45. Automatic Leveling . . . . .	4-5
2-5. Three-Conductor Power Cable . . . . .	2-1	4-48. RF Blanking . . . . .	4-5
2-8. Idle Heater . . . . .	2-1	4-50. Marker Generator . . . . .	4-5
2-10. Power Requirements . . . . .	2-1	4-56. Pip Marker Generator . . . . .	4-6
2-16. Repackaging for Shipment . . . . .	2-1	4-60. Composite Signal Amplifier . . . . .	4-6
III OPERATION . . . . .	3-1	4-63. Power Supply . . . . .	4-6
3-1. Panel Layout and Controls . . . . .	3-1	V MAINTENANCE . . . . .	5-1
3-4. Operating Instructions . . . . .	3-2	5-1. Introduction . . . . .	5-1
3-5. Operational Checks . . . . .	3-2	5-3. Test Equipment . . . . .	5-1
3-7. RF Oscillator and Amplifier . . . . .	3-2	5-5. Component Identification . . . . .	5-1
3-10. RF Output Attenuators . . . . .	3-3	5-7. Adjustments . . . . .	5-1
3-12. Crystal Referenced Frequencies . . . . .	3-3	5-11. Power Supply . . . . .	5-1
3-14. Pip and Crystal Markers . . . . .	3-3	5-12. Marker Amplifier Traps . . . . .	5-2
3-19. Test Signal Amplifier . . . . .	3-4	5-13. Marker Oscillators . . . . .	5-2
3-21. Amplitude Modulation . . . . .	3-4	5-14. Pip Markers . . . . .	5-2
3-23. RF Blanking and Flatness . . . . .	3-4	5-15. RF Output and AGC . . . . .	5-2
3-26. Using the Sweep Signal Generator . . . . .	3-4	5-17. AGC Adjustment . . . . .	5-3
3-29. RF Output . . . . .	3-4	5-18. Preliminary Frequency Adjustment . . . . .	5-3
3-31. Test Signal In . . . . .	3-4	5-20. CW Frequency Calibration . . . . .	5-3
3-33. Sweep Out . . . . .	3-4	5-21. Sweep Frequency Calibration . . . . .	5-3
3-36. Composite Signal Out . . . . .	3-5	5-23. Sweep Linearity . . . . .	5-3
IV PRINCIPLES OF OPERATION . . . . .	4-1	5-27. RF Level Meter . . . . .	5-5
4-1. Introduction . . . . .	4-1	5-28. AM Calibration . . . . .	5-5
4-3. CW Signal Generator . . . . .	4-1	5-29. Trouble Shooting and Repair . . . . .	5-5
4-8. Sweep Signal Generator . . . . .	4-2	5-30. Tube Replacement . . . . .	5-5
4-13. Reference Frequencies and Adder Stage . . . . .	4-2	5-32. Yoke and Range Switch Repair . . . . .	5-5
4-18. Pip Marker Generator . . . . .	4-2	5-34. Trouble Shooting Chart . . . . .	5-5
4-21. Power Supply . . . . .	4-2	5-36. Circuit Voltages . . . . .	5-5
4-23. RF Oscillator and Reactors . . . . .	4-3	5-38. Waveforms . . . . .	5-6
		5-40. Marker Ambiguity . . . . .	5-6
		VI REPLACEABLE PARTS . . . . .	6-1
		6-1. Introduction . . . . .	6-1
		6-3. Ordering Information . . . . .	6-1
		Reference Designation Index . . . . .	6-2

**LIST OF ILLUSTRATIONS**

Number	Title	Page
1-1.	Model 240A Sweep Signal Generator . . .	1-1
3-1.	Front Panel Control Layout . . . . .	3-0
3-2.	RF Sweep Flatness . . . . .	3-4
3-3.	Test Setup Using 501B Output Cable . . .	3-4
3-4.	Test Setup Using 501B Output Cable and 509B Attenuator . . . . .	3-4
4-1.	Functional Block Diagram - 240A . . . . .	4-1
4-2.	RF Oscillator . . . . .	4-3
4-3.	Buffer Amplifier and Diode Modulator . .	4-3
4-4.	Output Attenuator System. . . . .	4-4
4-5.	RF Output Characteristics . . . . .	4-4
4-6.	Sweep Control Waveforms . . . . .	4-4
4-7.	Automatic Leveling-Block Diagram . . .	4-5
4-8.	RF Blanking - Block Diagram . . . . .	4-5
4-9.	Crystal Markers - Block Diagram . . . .	4-5
4-10.	Pip Markers - Block Diagram . . . . .	4-6
4-11.	Composite Signal Amplifier . . . . .	4-6
4-12.	Power Supply - Block Diagram . . . . .	4-7
5-1.	Band 5 Linearity Presentation . . . . .	5-4
5-2.	Linearity Limits . . . . .	5-4
5-3.	Oscillator Tube Connections . . . . .	5-5
5-4.	RF Unit Terminal Board . . . . .	5-5
5-5.	Setup for Pip Identification . . . . .	5-6
6-1.	Major Subassemblies . . . . .	6-15
6-2.	Power Supply Chassis (Top) . . . . .	6-15

Number	Title	Page
6-3.	Power Supply Chassis (Bottom) . . . . .	6-16
6-4.	Marker Chassis . . . . .	6-16
6-5.	Sweep Chassis . . . . .	6-17
6-6.	Pip Chassis . . . . .	6-17
6-7.	Audio Chassis . . . . .	6-18
6-8.	RF Unit . . . . .	6-18
6-9.	Range Switch and Reactor Assembly . . .	6-18
	RF Unit, Audio Oscillator, Meter Circuit Schematic . . . . .	6-19
	Sweep and Pip Chassis Schematic . . . .	6-21
	Marker Chassis Schematic . . . . .	6-23
	Power Supply Schematic . . . . .	6-25

**LIST OF TABLES**

Number	Title	Page
1-1.	Specifications . . . . .	1-0
3-1.	Control Settings for CW and Sweep Operation . . . . .	3-3
5-1.	Recommended Test Equipment . . . . .	5-0
5-2.	Component Identification . . . . .	5-0
5-3.	CW Frequency Calibration . . . . .	5-3
5-4.	Center Frequency Calibration . . . . .	5-3
5-5.	Trouble Shooting Chart . . . . .	5-6
5-6.	Voltage Chart . . . . .	5-8
	Reference Designation Index . . . . .	6-2

<p><b>Radio Frequency Characteristics</b> <b>RF RANGE:</b> Total Range: 4.5 to 120 Mc. No. Bands: 5 Band Ranges: 4.5 — 9 Mc. 35 — 75 Mc. 9 — 18 Mc. 75 — 120 Mc. 18 — 35 Mc. <b>RF ACCURACY:</b> <math>\pm 1\%</math>* (after four hour warmup). *May be standardized against internal crystal to <math>\pm 0.005\%</math>. <b>RF CALIBRATION:</b> Increments of approximately 1%. <b>RF OUTPUT:</b> Range: 1 <math>\mu\text{V}</math> to 0.3 volts* (sweep). 1 <math>\mu\text{V}</math> to 0.1 volts* (CW &amp; AM). *Across external 50 <math>\Omega</math> load. Accuracy: <math>\pm 20\%</math> of full scale RF level meter reading. Impedance: 50 <math>\Omega</math>* *25 <math>\Omega</math> at terminals of Type 501-B Output Cable.</p> <p><b>Swept Frequency Characteristics</b> <b>SWEEP RANGE:</b> Internal: <math>\pm 1\%</math> to <math>\pm 15</math> Mc. or <math>\pm 30\%</math> of center frequency, whichever is smaller. External: <math>\pm 1\%</math> to <math>\pm 12</math> Mc. or <math>\pm 24\%</math>* of center frequency, whichever is smaller. (20 to 200 cps. repetition rate). *Decreases to <math>\pm 0.75</math> Mc. or <math>\pm 1.5\%</math> at 1000 cps. repetition rate. <b>SWEEP LINEARITY:</b> <math>\pm 10\%</math> over central <math>\pm 80\%</math> of sweep excursion. <math>\pm 20\%</math> over outer 20% of sweep excursion. <b>OUTPUT FLATNESS:</b> Flat within <math>&lt;7\%</math>. <b>REPETITION RATE:</b> Internal: 20 to 70 cps.* External: 20 to 1000 cps. *Provision for synchronization with line frequency. <b>BLANKING:</b> Internal blanking of RF output provides zero base line display during return cycle of internal sweep. <b>SWEEPING VOLTAGE OUTPUT:</b> 20 volts P-P (triangular waveform) available at front panel posts.</p> <p><b>Marker Characteristics</b> <b>CRYSTAL BIRDIE MARKERS:</b> Frequency: 01., 0.5, and 2.5 Mc. Accuracy: <math>\pm 0.005\%</math></p>	<p><b>PIP MARKERS:</b> No. of Markers: 2 Position: Continuously adjustable to any position on sweep excursion.</p> <p><b>INTERNAL MIXER:</b> Function: Adds markers to output of circuit under test. Markers do not pass through circuit under test. Gain: Approximately <math>10^*</math>. *For input level range 0.1 to 5 volts P-P.</p> <p><b>Amplitude Modulation Characteristics</b> <b>AM LEVEL:</b> Approximately 30% from internal 1000 cps. oscillator.</p> <p><b>Physical Characteristics</b> <b>MOUNTING:</b> Cabinet for bench use (19" rack mount available on special order). <b>FINISH:</b> Gray wrinkle, engraved panel (other finishes available on special order). <b>DIMENSIONS:</b> Height: 18" (45.7 cm) Width: 14½" (36.8 cm) Depth: 19¼" (48.9 cm) <b>WEIGHT:</b> Net: 76 lbs. (34.2 kg) Gross Export: 168 lbs. (75.6 kg) Gross Domestic: 100 lbs (45 kg) Legal Export: 92 lbs. (41.4 kg)</p> <p><b>Accessories</b> <b>FURNISHED:</b> Type 501-B Output Cable. <b>AVAILABLE:</b> Type 502-B Patching Cable. Type 506-B Patching Cable. Type 509-B Attenuator. Type 514-B Output Cable.</p> <p><b>Power Requirements</b> 240-A: 105-125 volts, 60 cps., 280 watts. 240-AP: 105-125 volts, 50 cps., 280 watts.</p>
---	---

Table 1-1. Specifications

## SECTION I

### GENERAL

#### 1-1. INTRODUCTION.

1-2. The Sweep Signal Generator Model 240A has been designed for use in the development and testing of radio frequency pass-band amplifiers over the frequency range of 4.5 to 120 mc. The 240A is shown in Figure 1-1. It consists of (1) a precision CW signal Generator which may be amplitude modulated, (2) a Swept Frequency Generator providing linear frequency deviation over the range from plus and minus 1% of the center frequency to plus and minus 30% of the center frequency, or 15 mc, whichever is smaller, and (3) a Marker System producing (a) crystal referenced birdie-type markers, (b) adjustable pip interpolation markers, and (c) a composite signal containing the markers added to the response of the system under test. Complete specifications are given in Table 1-1.

1-3. A precision output attenuator system operates on both cw and swept outputs. Provisions are included for sweeping from an external source of sweeping voltages and for providing to an oscilloscope the synchronized sweep voltage.

#### 1-4. SUPPLIED ACCESSORY 501B.

1-5. The Model 501B Output Cable accessory is included with the 240A for connection to circuits. The 501B is a shielded cable with a BNC male connector on one end and a moulded holder with two binding posts at the other. A 50-ohm terminating resistor is internally connected across the terminals.



Figure 1-1. Model 240A Sweep Signal Generator



### SECTION 1

### CHAPTER 1

The first part of the document discusses the importance of maintaining accurate records. It emphasizes that proper record-keeping is essential for ensuring the integrity and reliability of the data collected. This section also outlines the various methods used to collect and analyze the data, highlighting the challenges faced during the process. The authors note that while the data is extensive, it is not without its limitations, and they provide a detailed explanation of these limitations. The document concludes with a summary of the findings and a discussion of the implications for future research.



## SECTION II

### INSTALLATION

#### 2-1. INTRODUCTION.

2-2. This section contains information on unpacking inspection, repacking and installation.

#### 2-3. UNPACKING AND INSPECTION.

2-4. Inspect instrument for shipping damage as soon as it is unpacked. Check for broken knobs and connectors; inspect cabinet and panel surfaces for dents and scratches. An operation check is given in Paragraphs 3-7 through 3-25. If instrument is damaged in any way or fails to operate properly, notify carrier immediately (see warranty statement on the inside front cover of this manual). For assistance of any kind, including help with instruments under warranty, contact your Hewlett-Packard field office.

#### 2-5. THREE-CONDUCTOR POWER CABLE.

2-6. To protect operating personnel, the National Electrical Manufacturers' Association (NEMA) recommends that the instrument panel and cabinet be grounded. All Hewlett-Packard instruments are equipped with a three-conductor power cable which, when plugged into an appropriate receptacle, grounds the instrument. The offset pin on the power cable three-prong connector is the ground wire.

2-7. To preserve the protection feature when operating the instrument from a two-contact outlet, use a three-prong to two-prong adapter and connect the green pigtail on the adapter to ground.

#### 2-8. IDLE HEATER.

2-9. In the off position of the power switch, a 30-watt heater is turned on in the RF Unit to maintain a near-operating temperature in the frequency determining circuitry to reduce required warmup time when the 240A is turned on.

#### 2-10. POWER REQUIREMENTS.

2-11. The Model 240A contains a voltage stabilizer to regulate some internal voltages. Since the performance of the stabilizer is based on a rated power line frequency, the line voltage and frequency rating shown on the plate above the power receptacle on the rear of the cabinet must be observed.

2-12. The 240A is available for use on the following power line sources only:

1. Model 240A: 105-125 volts, 60 cps
2. Model 240AP: 105-125 volts, 50 cps

CAUTION: Use of a power source other than that specified on the voltage plate will result in damage to the 240A.

2-13. For use on 220 volts, an external transformer (-hp- #9100-0401) must be used to drop the line voltage to the range of 105 to 125 volts.

2-14. Power consumption for either the 240A or 240AP is approximately 280 watts.

2-15. A time delay switch with 30 seconds lag allows tube filaments to warm up before the application of plate voltage.

#### 2-16. REPACKAGING FOR SHIPMENT.

2-17. The following is a general guide for repacking for shipment. If you have any questions, contact your local -hp- Sales and Service Office (see lists at rear of this manual).

a. Place instrument in original container if available. If original container is not available, it can be purchased from your nearest -hp- Sales and Service Office.

If original container is not used:

b. Wrap instrument in heavy paper or plastic before placing in an inner container.

c. Use plenty of packing material around all sides of instrument and protect panel faces with cardboard strips.

d. Place instrument and inner container in a heavy carton or wooden box and seal with strong tape or metal bands.

e. Mark shipping container with "Delicate Instrument", "Fragile", etc.

NOTE: If the instrument is to be shipped to Hewlett-Packard for service or repair, attach to the instrument a tag identifying the owner and indicate the service or repair to be accomplished; include the model number and serial number of the instrument. In any correspondence, identify the model and serial numbers

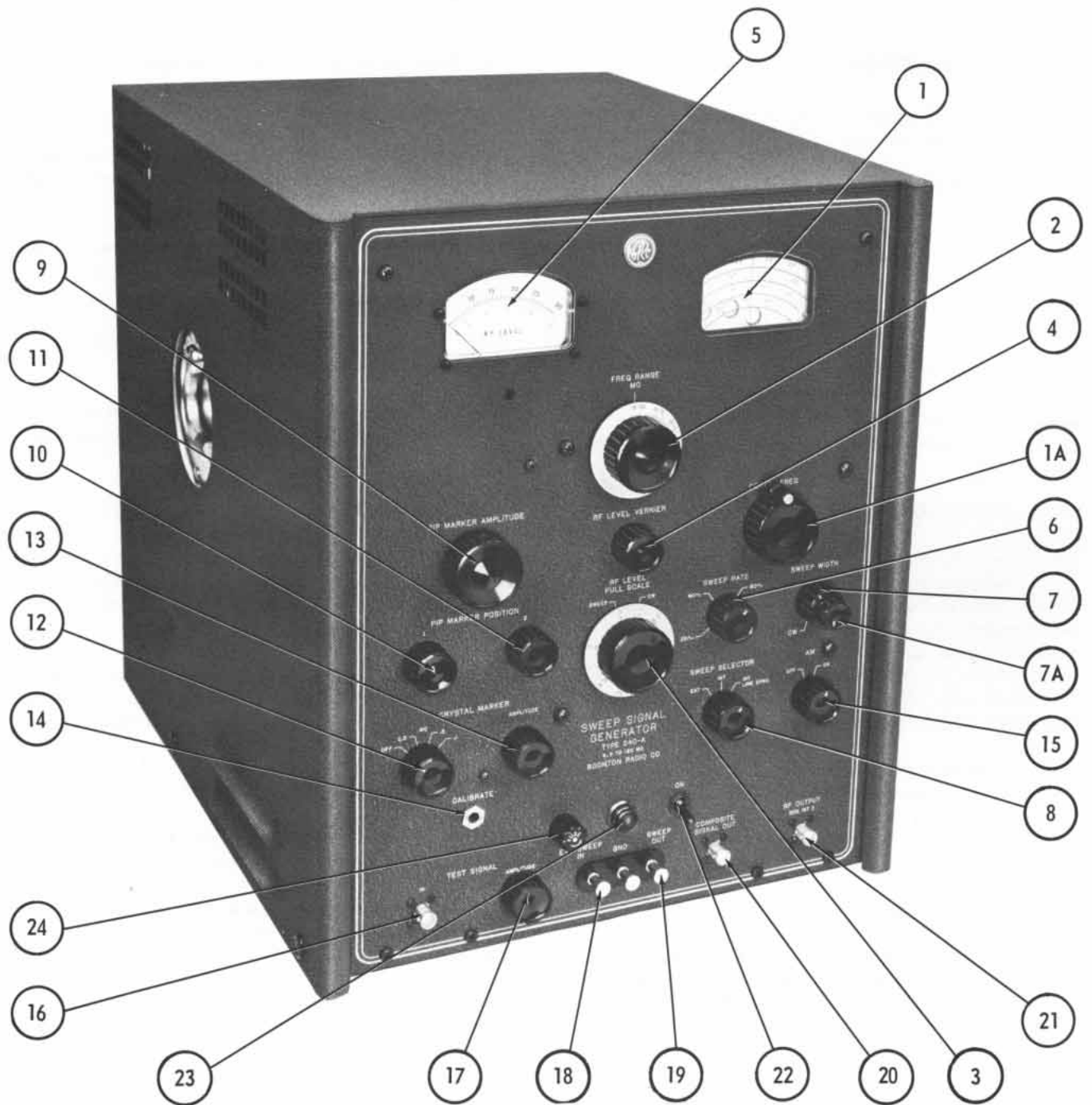

Figure 3-1. Front Panel Control Layout

## SECTION III

### OPERATION

#### 3-1. PANEL LAYOUT AND CONTROLS.

3-2. On the front panel, all controls associated with a given function are grouped, with those controls most frequently used given preferred locations. A meter provides good readability of the output functions of the generator. All cable connections in and out of the instrument are located along the bottom of the front panel. The front view of the Sweep Signal Generator Model 240A, Figure 3-1, shows the various controls, meters and measuring circuit connections. The four controls associated with operation as a sweep generator are grouped on the right side and the controls for the two Marker Systems are grouped on the left. Power controls and indicators are centrally located near the bottom of the instrument. All connections into and out of the generator are grouped along the bottom of the cabinet; inputs on the left, outputs on the right.

3-3. In the following description, front panel designations are shown within quotation marks:

#### 1. CENTER FREQUENCY DIAL

The five-band frequency dial, visible in the upper right hand window, indicates the center frequency of the output signal in megacycles. The red circle on the fiducial line indicates the active range. The total range of 4.5 - 120 mc is covered in five ranges of 4.5-9, 9-18, 18-35, 35-75 and 75-120 mc.

#### 1A. Center Frequency Control Knob "CENTER FREQ"

The center frequency control knob operates the frequency dial (1).

#### 2. Frequency Range Knob "FREQ RANGE-MC"

The dial-type frequency range knob indicates the frequency range of the output signal.

#### 3. Step Attenuator Control Knob "RF LEVEL-FULL SCALE"

The dial-type step attenuator control knob contains two scales, one red (0-10) and one black (10-30) which are keyed to the corresponding colors on the RF level meter. The dial is marked in terms of open-circuit voltage across the output terminals of a 501B output cable.

#### 4. Output Level Vernier Control "RF LEVEL-VERNIER"

The output level vernier control adjusts the output within the range of each step of the step attenuator (3).

#### 5. Output Meter "RF LEVEL METER"

The output meter indicates the RF output of the 240A as adjusted by the Step Attenuator control (3) and output level vernier (4).

#### 6. Sweep Rate Control Knob "SWEEP RATE 20~ - 40~ - 60~"

The Sweep Rate Control adjusts the repetition rate of the internal sweep continuously from 20 to 70 cps.

#### 7. CW-Sweep Selector Knob "CW - SWEEP"

The CW-Sweep Selector knob disables the sweep circuits in the CW position.

#### 7A. Sweep Width Control Knob "SWEEP WIDTH"

The Sweep Width control adjusts the frequency deviation when the CW-Sweep Selector (7) is in the sweep position.

#### 8. Sweep Selector Knob "SWEEP SELECTOR"

The Sweep Selector knob indicates the source of the Sweep Signal; external, internal or internally synchronized to the power line frequency.

#### 9. Pip Marker Amplitude Control Knob "PIP MARKER AMPLITUDE"

The Pip Marker Amplitude controls the amplitude of the Pip Markers as observed on an oscilloscope associated with sweep testing procedures.

#### 10 and 11. Pip Marker Position Control Knobs "PIP MARKER POSITION"

The Pip Mark Position controls adjust the position of the Pip Markers along the trace as observed on an oscilloscope. Each Pip Marker operates independently.

#### 12. Crystal Marker Selector Knob "CRYSTAL MARKER - MC"

The Crystal Marker Selector selects the intervals between the crystal marker birdies as observed on the oscilloscope trace; i.e., 2.5 mc, .5 mc, or .1 mc intervals.

#### 13. Crystal Marker Amplitude Control Knob "CRYSTAL MARKER-AMPLITUDE"

The Crystal Marker Amplitude control adjusts the amplitude of the crystal markers as observed on the oscilloscope trace. This control will allow adjustment of the markers to obtain good resolution when adjusting the Pip Markers.

#### 14. Calibrate Phone Jack "CALIBRATE"

The calibrate phone jack is used to calibrate the

center frequency dial by zero beating the CW RF output with the proper crystal marker harmonic. High impedance headphones or an oscilloscope is used to determine zero beat.

15. AM Selector Control Knob "AM - ON - OFF"

The AM Selector allows the CW output of the 240A to be 30% amplitude modulated by a 1 kc audio signal. The frequency and the percent of AM is not externally adjustable.

16. Test Signal Input Connector "TEST SIGNAL-IN"

The test signal input BNC connector is used to add the externally detected RF signal to the internally generated pips and birdies to form the composite signal output for the oscilloscope display.

17. Test Signal Amplitude Control Knob "TEST SIGNAL-AMPLITUDE"

The Test Signal Amplitude control adjusts the level of the incoming signal applied to the test signal input connector (16). This control effects the signal level from the composite signal output connector (20).

18. External Sweep Input Terminal "EXT SWEEP-IN"

The external sweep input terminals allow the 240A to be swept, externally, at any repetition rate from 20 cps to 1 kc.

19. Internal Sweep Output Terminal "SWEEP OUT"

The internal sweep output terminal is to provide the internal sweep signal to the horizontal input of an oscilloscope. This sweep output is synchronized with the RF output sweep signal.

20. Composite Signal Output Connector "COMPOSITE SIGNAL OUT"

The composite signal output connector provides the detected RF output signal added to the internally generated pip and birdie markers for display on an oscilloscope.

21. RF Output Connector "RF OUTPUT - 50Ω INT Z"

22. Power Switch "ON"

This switch applies power to the Signal Generator when in the ON position. In the OFF position power is applied to an idle heater (R455) in the RF Unit to maintain near operating temperature in the frequency determining section of the 240A to reduce warmup time.

NOTE: To completely shut down the 240A Signal Generator the Power Cord must be disconnected from the Power Source.

23. Pilot Light

The Pilot Light indicates that power is connected

to the operating circuits of the 240A. The Pilot Light does not indicate operation of the RF Unit idle heater (R455).

24. Fuse "FUSE"

This 3 ampere fuse is connected in the ac line.

### 3-4. OPERATING INSTRUCTIONS.

CAUTION: Use of a power source other than that specified on the plate will result in damage to the instrument.

1. Plug the power cord into a source of voltage. (See paragraph 2-11.)

NOTE: In the OFF position of the power switch a 30-watt heater is turned on in the RF Unit to maintain near-operating temperature in the frequency determining circuitry to reduce required warmup time when the instrument is turned on.

2. Turn the "RF LEVEL VERNIER" knob off (counter-clockwise) as far as it will go. This protects the meter during warmup. Turn the Power Switch located at the lower center of the front panel, to the ON position.

3. Attach the RF Output Cable Type 501B to the front panel RF OUTPUT jack.

#### 4. CONTROL SETTINGS

Table 3-1 gives the positions of the controls for use as a CW Signal Generator or as a Sweep Signal Generator at a 60 cps rate.

### 3-5. OPERATIONAL CHECKS.

- 3-6. Normal operation of the instrument can be checked as follows:

#### 3-7. RF OSCILLATOR AND AMPLIFIER.

3-8. After a delay of approximately 30 seconds introduced by the thermal time delay tube in the high voltage power supply, the RF LEVEL meter should rise when the RF LEVEL VERNIER knob is rotated in a clockwise direction. It should be possible to obtain full-scale reading on this meter with less than full rotation of the RF LEVEL VERNIER knob at all frequencies on all bands.

3-9. With the RF LEVEL VERNIER knob turned down, the RF LEVEL meter should indicate less than the lowest calibration line, but not zero. Since this meter is monitoring the RF output immediately ahead of the attenuator system, this check proves that the Power Supply, Oscillator and Buffer Amplifier systems are operating satisfactorily.

Table 3-1. Control Settings for CW and Sweep Operation

Control	CW-AM	Sweep
FREQ RANGE	Select frequency range	
CENTER FREQ	Adjust frequency dial	
RF LEVEL FULL SCALE	Select output range	
RF LEVEL VERNIER	Adjust meter level	
AM	OFF or ON	OFF
CW - SWEEP	CW	SWEEP
SWEEP SELECTOR	not used	INT LINE SYNC
SWEEP RATE	not used	60~
SWEEP WIDTH	not used	start full clockwise
PIP MARKER AMPLITUDE	not used	increase clockwise
PIP MARKER POSITION 1 2	not used not used	start full counter-clockwise start full counter-clockwise
CRYSTAL MARKER MC AMPLITUDE	calibration only calibration only	ON then OFF increase clockwise
TEST SIGNAL AMPLITUDE	not used	increase clockwise

**3-10. RF OUTPUT ATTENUATORS.**

3-11. Set the FREQUENCY RANGE control to the 4.5-9.0 MC range, the CW-SWEEP selector to CW, and the FREQUENCY DIAL, by means of the CENTER FREQUENCY knob, to 5 MC. A suitable RF voltmeter (such as an -hp- 411A) connected across the terminals of the 501B Output Cable should show an RF voltage when the RF LEVEL VERNIER and RF LEVEL FULL SCALE controls are set for full output.

**3-12. CRYSTAL REFERENCED FREQUENCIES.**

3-13. Connect a pair of high impedance earphones to the CALIBRATE jack, turn the CRYSTAL MARKER selector switch to 2.5 MC, and the CW-SWEEP selector to CW. A whistle, or heterodyne beat note, should be heard in the phones as the CENTER FREQUENCY tuning control is rotated past integral multiples of 2.5 mc. A similar check at 0.5 mc spacing and 0.1 mc spacing will demonstrate whether CRYSTAL MARKER system is operating normally. It will also serve to check the accuracy of the frequency calibration of the FREQUENCY DIAL. During this check it is necessary to have the CRYSTAL MARKER AMPLITUDE CONTROL turned on full.

**3-14. PIP AND CRYSTAL MARKERS.**

3-15. Connect the SWEEP OUT terminals to the horizontal input on the oscilloscope. The gain of the oscilloscope should be adjusted to produce a normal horizontal trace. Connect the COMPOSITE SIGNAL OUT jack to the vertical input of the oscilloscope. Set the CW-SWEEP selector to SWEEP.

3-16. In the absence of a test signal and with the CRYSTAL MARKERS turned OFF, there should be a horizontal line on the oscilloscope containing two pip markers whose horizontal positions along the trace are adjustable by the means of the two independent PIP MARKER POSITION controls on the front panel. The amplitude of the pips should be adjustable by means of the PIP MARKER AMPLITUDE control.

3-17. The position of the pips is determined from the leading edge of the sweep, independent of sweep width. The voltage delivered to the SWEEP OUT terminals also should be independent of the sweep width. Rotation of the SWEEP WIDTH knob should not affect the position of the pip markers, nor the width of the trace on the oscilloscope.

3-18. Set the SWEEP WIDTH control about half way to maximum, turn the CRYSTAL MARKER switch on, and advance the CRYSTAL MARKER AMPLITUDE. Birdie-type markers should appear on the oscilloscope. The number of markers depends on the marker separation and the SWEEP WIDTH setting.

3-19. TEST SIGNAL AMPLIFIER.

3-20. An audio frequency signal of approximately 1/2 volt applied to the TEST SIGNAL IN jack should appear at the COMPOSITE SIGNAL OUT jack as approximately 4 volts with the TEST SIGNAL-AMPLITUDE control turned full on.

3-21. AMPLITUDE MODULATION.

3-22. Connect a diode detector circuit across the terminals of the 501B Output Cable and connect the rectified output to the vertical input of the oscilloscope. Turn the RF LEVEL controls for full output, the function selector knob to CW, and the AM knob to ON. Adjust the internal linear sweep of the oscilloscope for about 100 cps. The rectified 1000 cps amplitude modulation should appear on the oscilloscope.

3-23. RF BLANKING AND FLATNESS.

3-24. Use the diode detector and oscilloscope connections of paragraph 3-22 with the oscilloscope sweep rate set to 20 cps. Turn the CW-SWEEP selector knob to SWEEP and turn the SWEEP WIDTH control up about half way.

3-25. The oscilloscope waveform is shown in Fig. 3-2. The top line (demodulated RF) and bottom line (base line) should be parallel and flat.

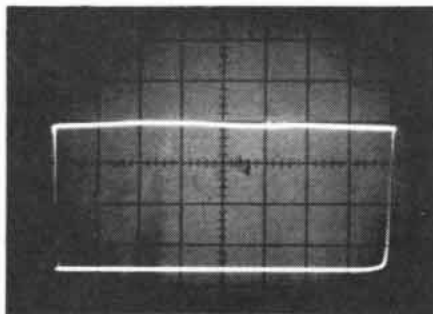

Figure 3-2. RF Sweep Flatness

3-26. **USING THE SWEEP SIGNAL GENERATOR.**

3-27. For use as a conventional CW or Amplitude Modulated Signal Generator, the only connection required is the 501B RF Output Cable.

3-28. Figures 3-3 and 3-4 show typical arrangements of test equipment for measuring the pass-band of a radio frequency amplifier having its own detector.

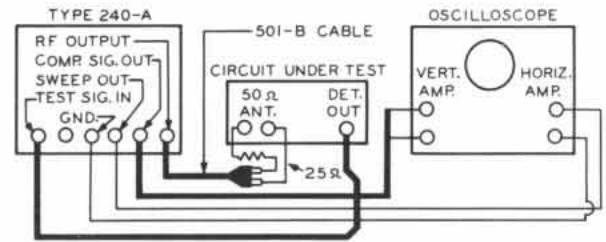

Figure 3-3. Test Setup Using 501B Output Cable

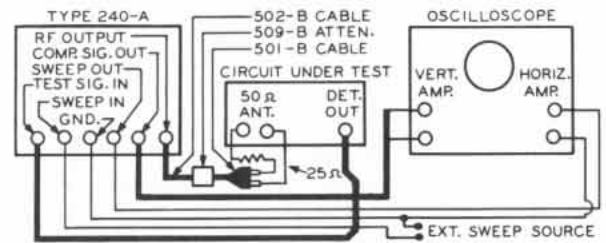

Figure 3-4. Test Setup Using 501B Output Cable and 509B Output Cable

3-29. RF OUTPUT.

3-30. The RF output is obtained from the terminals of the 501B cable, which presents a source impedance of 25 ohms. The open-circuit voltage, acting in series with 25 ohms, is indicated by the combination of the meter and the RF LEVEL FULL SCALE dial. An additional 25-ohm series resistor must be placed between the high terminal of the 501B cable and the input to a 50-ohm receiver.

3-31. TEST SIGNAL IN.

3-32. The detected output voltage of the circuit under test is fed to the TEST SIGNAL IN jack.

3-33. SWEEP OUT

3-34. The SWEEP OUT and GND terminals are connected to the horizontal input of the oscilloscope.

3-35. The SWEEP WIDTH control determines the frequency deviation about the indicated center frequency. (See Sweep Range in Table 1-1.)

NOTE: The system used for deviating an RF signal about a center frequency depends upon changing magnetic flux acting upon ferrite cores in the RF oscillator coils. The center frequency, as indicated by the frequency dial, is determined by the current in a coil which is magnetically coupled to the ferrite core. Residual magnetism in the ferrite and iron cores can cause the center frequency calibration to be slightly off. Rotating the SWEEP WIDTH control fully clockwise and then counter-clockwise will effect the degaussing of the cores and return the instrument to proper calibration.

3-36. COMPOSITE SIGNAL OUT.

3-37. The COMPOSITE SIGNAL OUT jack is connected to the vertical input of the oscilloscope. This signal contains the response pattern of the system being tested, the Crystal Markers, if they are turned ON, and the Pip Markers.

3-38. When a 509B 20-db Attenuator is inserted between a 502B Cable and a 501B Output Cable, as shown in Figure 3-4, all output readings on the signal generator should be divided by 10. The unloaded output voltage appearing across the terminals at the end of the 501B Cable will be 1/10 the indicated voltage in series with 50 ohms:



## SECTION IV

### PRINCIPLES OF OPERATION

#### 4-1. INTRODUCTION.

4-2. Figure 4-1 shows the functional block diagram of the Sweep Signal Generator Model 240A. It performs the functions of four instruments with a common power supply in a single case. Each of these functions will be discussed separately.

1. A Precision CW Signal Generator.
2. A Sweep Frequency Generator.
3. A Crystal-Controlled Source of Reference Frequencies and an Adder Stage.
4. A Double-Pip Interpolation Marker Generator.

#### 4-3. CW SIGNAL GENERATOR.

4-4. The frequency band from 4.5 to 120 Mc is tuned in five ranges by a variable air capacitor and five oscillator coils. The oscillator operates at the fundamental frequency marked on the frequency dial. The broad-band, untuned buffer-amplifier feeds this signal to a variable 10 db "L" pad attenuator which is followed by a step attenuator having 10 steps of 10 db each. A diode voltmeter monitors the output of the "L" pad. The attenuator system produces calibrated voltage levels at the output of the cable, ranging from 0.3 volt full scale to 1 microvolt at the lowest calibration point on the monitoring voltmeter combined with the maximum attenuation of the step attenuator.

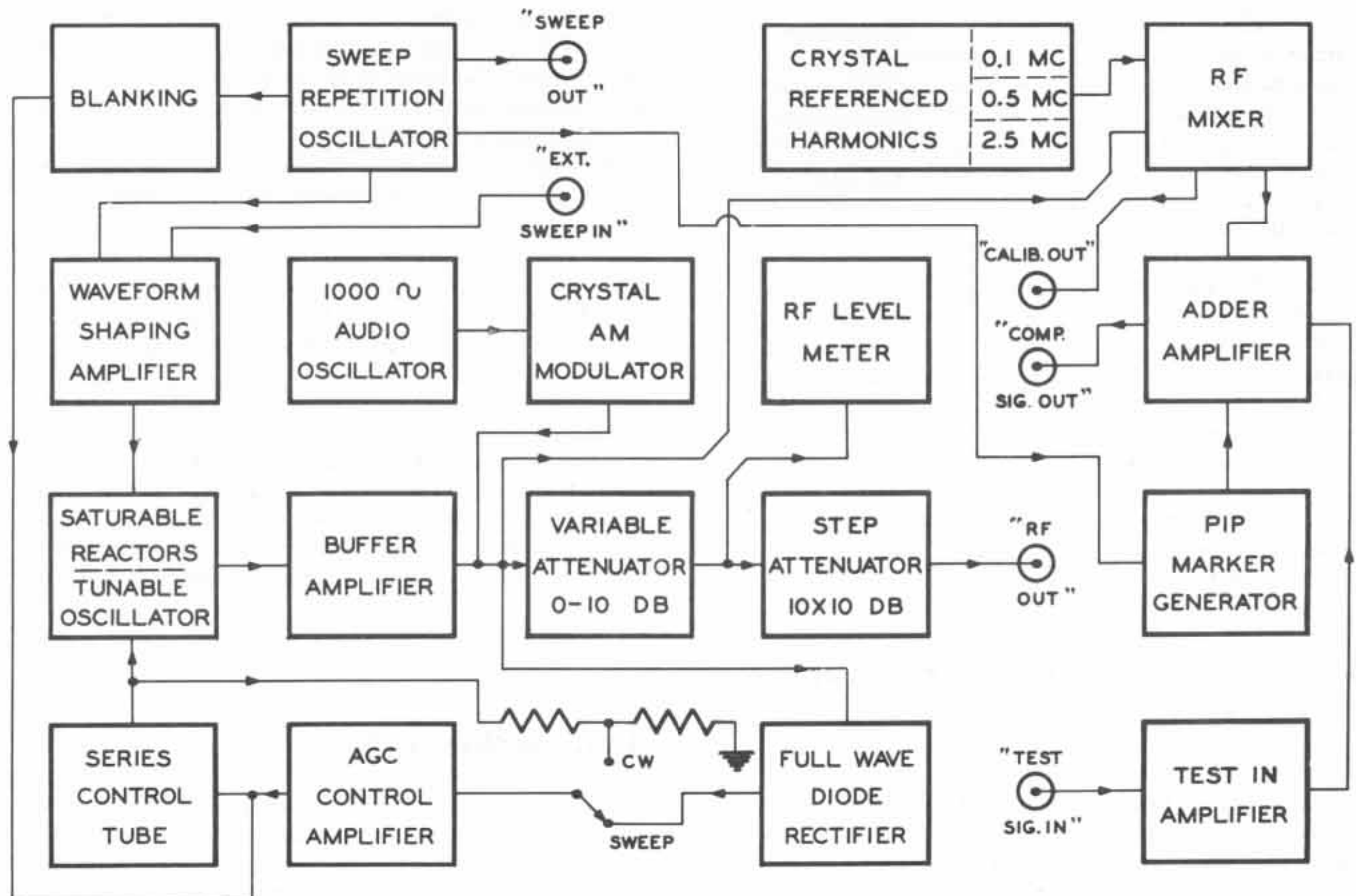

Figure 4-1. Functional Block Diagram - 240A

4-5. Stray field leakage from the instrument has been held at a sufficiently low level so that an external 20 db pad, such as the 509B Attenuator, can be used for making measurements below the range of the direct output of the generator.

4-6. In shunt with the output system is a crystal diode amplitude modulator adjusted for modulating the output to 30%. A 1000 cps audio oscillator drives the amplitude modulator.

4-7. When the CW Signal Generator is used in conjunction with the self-contained crystal-referenced harmonic generator, the frequency calibration can be checked by means of phones or an oscilloscope connected to the calibrate output jack for indicating zero beats.

#### **4-8. SWEEP SIGNAL GENERATOR.**

4-9. The radio frequency signals described above may be caused to deviate about the center frequency by varying the magnetic flux passing through the ferrite cores upon which are wound the five oscillator coils. The current through a coil and yoke assembly establishes the correct operating point for the saturable reactors.

4-10. The current waveform necessary to produce linear deviation of frequency is generated from the output of an adjustable-frequency multivibrator circuit covering the frequency range from 20 to 70 cps. It may be synchronized to the line frequency. A triangular waveform of voltage appears at the front panel of the instrument for driving the horizontal input of the oscilloscope.

4-11. The width of sweep is adjustable and is symmetrical about the center frequency shown on the frequency tuning dial. A binding post on the front panel permits the use of external sweeping voltages in place of those generated internally. An automatic gain control system holds the output constant while the frequency is being swept.

4-12. The attenuator output system and level-monitoring meter apply equally to the CW, AM and Swept outputs.

#### **4-13. REFERENCE FREQUENCIES AND ADDER STAGE.**

4-14. A set of reference frequencies ("birdies"), which are harmonically related, is generated by a system of three separate oscillators referenced to a quartz crystal. A front panel control permits the choice of the harmonically related frequencies spaced 2.5 Mc, 0.5 Mc, or 0.1 Mc. The number of "birdies" depends on the bandwidth of the signal circuit under test.

4-15. The spectrum of harmonically related frequencies is heterodyned with the swept RF output of the buffer amplifier in a mixer stage to produce a series of audio frequency beat notes, passing a zero beat, as the swept frequency passes through the reference frequencies. These audio frequency beat notes ("birdies") are fed to an audio frequency Adder Amplifier.

4-16. The rectified response from the circuit under test is fed into the Test Signal Amplifier and combined with the birdie markers, thus producing a "COMPOSITE SIGNAL OUTPUT" which provides accurate identification of the instantaneous frequency being applied to the input of the system under test. The "birdie" markers are not added to the RF output of the 240A and therefore will have no effect on the circuits under test.

4-17. The reference frequencies ("birdies") can be used for calibrating the center frequency dial of the signal generator.

#### **4-18. PIP MARKER GENERATOR.**

4-19. A unique feature of this instrument is the inclusion of two sharp, rectangular "pip" markers whose horizontal position on the oscilloscope trace can be independently controlled and whose position is synchronized with the beginning of the sweep trace. This system makes it possible to accurately mark the center of the birdie-type markers on a display pattern. When the crystal reference birdie markers are turned off, the clean-cut, pip markers will remain on the oscilloscope display. These pip markers identify the center of the reference frequencies, with crystal accuracy, without disturbing the pass-band pattern.

4-20. Either or both of the pip markers can be used as interpolation markers to identify frequencies other than those provided by the crystal markers, if a ruled grid is used on the oscilloscope screen. The two markers can be displaced completely to the left-hand end of the trace, if their use is not required.

#### **4-21. POWER SUPPLY.**

4-22. Filament power for critical tubes is obtained through a voltage-regulating transformer which must match the frequency of the power source: 60 cps for the Model 240A; 50 cps for the Model 240AP. High voltage and bias supplies contain electronic glow discharge type voltage regulator systems to assure stable operation from 105-125 volts.

**4-23. RF OSCILLATOR AND REACTORS.**

4-24. The oscillator of the 240A Signal Generator operates at the output frequency shown on the frequency dial on all bands. It consists of two Type 5718 Tubes (V-402, and V-403) operating in a push-pull oscillator circuit. The full frequency coverage of 4.5 to 120 Mc is covered in five bands, each of which has its own center-tapped coil, T401 through T405, wound on ferrite cores.

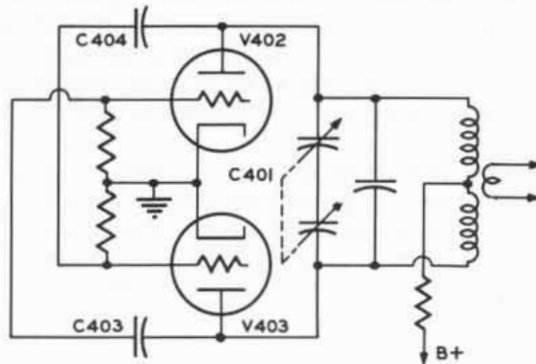

Figure 4-2. RF Oscillator

4-25. The ferrite cores have the property of changing their effective permeability as a function of the magnetic flux flowing through the core parallel with the axis of the coil. In operation this flux has two components. The dc component produced by the steady value of dc current through the exciting winding of the yoke system, provides the proper inductance at the center frequency. Superimposed on this direct current in the yoke coil is an alternating current consisting of an essentially triangular waveform of current which has been shaped in such a manner that the net change of frequency of the circuit will be linear with respect to the voltage delivered to the SWEEP OUT binding post.

4-26. Shaping of the current is required for two reasons. First, the ferrite does not respond linearly to the driving flux over the entire sweep range. Secondly, even if the ferrite produced a linear change of inductance of the coil itself as a function of current, the frequency would not change linearly due to square root relation between inductance and frequency and also because of the fact that the amount of varying inductance contained on the coil winding itself is in series with the fixed inductance of the switch and leads. It is therefore necessary to pre-emphasize the high-current portion of the waveshape independently on each band. See "Shaping Circuits" for details.

4-27. The filaments of the oscillator tubes are fed from the voltage stabilizer T602, through filament transformer T604. The plate supply to the oscillator is fed through a series regulator tube, V509, which

controls the output amplitude of the oscillator. This control signal is derived either from the automatic gain control amplifier system, V507, V508, V509, which monitors the output during the sweeping operation by diodes, CR402 and CR403; or from the fixed voltage divider on the plate supply of the oscillator consisting of resistors R567 and R517 during CW operation.

**4-28. BUFFER AMPLIFIER.**

4-29. The output of the oscillator is obtained by pick-up coils of T401 through T405, wound on the middle of the oscillator coil assemblies. These coil connections are picked up through contacts on the rotary band switch, S402, and fed to the input terminals of a grounded-grid, broad-band 6BK7A buffer amplifier, V401, which covers the band of 4.5 to 120 Mc. The RF voltage appearing at the output of the suppressor resistors, R422 and R423, feeds the input to an adjustable "L" pad attenuator, R431A, R431B, which is uncalibrated.

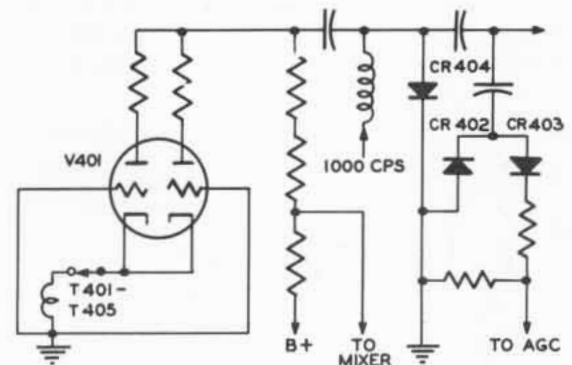

Figure 4-3. Buffer Amplifier and Diode Modulator

**4-30. AMPLITUDE MODULATOR.**

4-31. The RF voltage delivered at the output of the buffer amplifier appears across the diode modulator circuit, CR404 and L406. The 1000 cps voltage received from the r-c audio oscillator, V301, is applied as a dynamic operating bias on the diode CR404. This bias varies the impedance of the diode in such a manner as to form a variable shunt across the RF output system, thus producing amplitude modulation.

**4-32. OUTPUT ATTENUATOR.**

4-33. The RF voltage from the buffer amplifier, V401, is delivered to an "L" pad attenuator consisting of two ganged potentiometers, R431A and R431B. The output of the "L" pad attenuator is monitored by a crystal diode CR401, whose output appears on the RF LEVEL METER, M401. The "L" pad has an operating range somewhat in excess of 10 db.

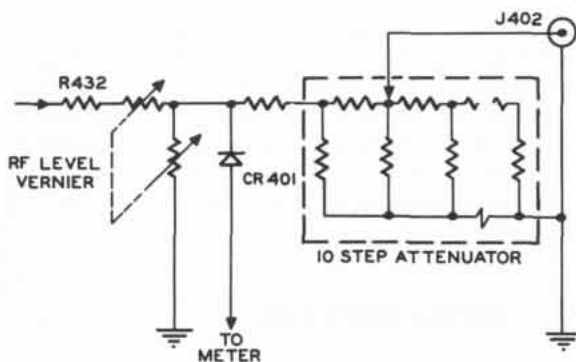

Figure 4-4. Output Attenuator System

4-34. The output of the "L" pad is fed to a 10-step attenuator unit AT401, having 10 db per step. The output impedance of the step attenuator is 50 ohms resistive except on the maximum output position in which case the impedance rises somewhat. The output of the attenuator is connected with the front panel RF OUTPUT jack, J402, by a 50-ohm coaxial cable.

4-35. The equivalent voltage source of the output system is shown in the diagrams of Figure 4-5. For 50 ohms impedance, add an external 25-ohm resistor.

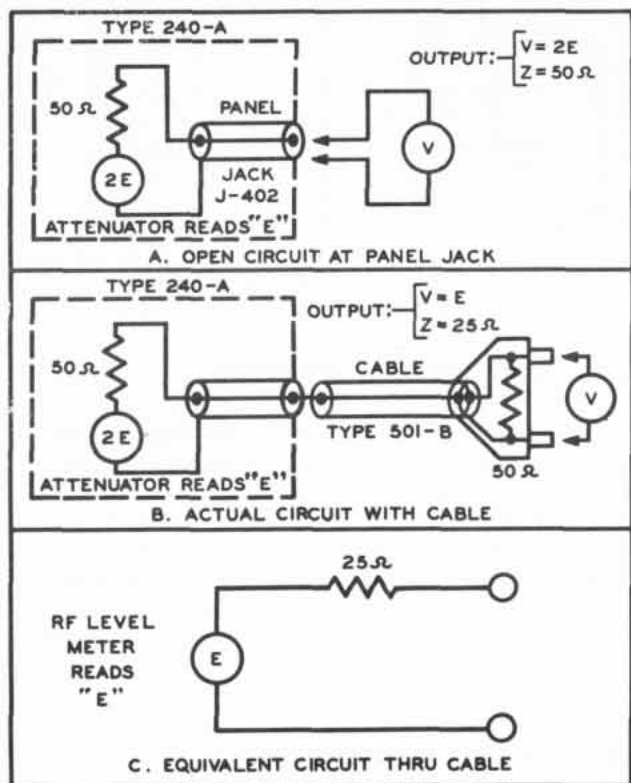

Figure 4-5. RF Output Characteristics

#### 4-36. SWEEP GENERATOR.

4-37. The repetition rate of the sweep voltage applied to the saturable reactor is controlled in the

multi-vibrator oscillator V501 by means of the ganged potentiometers R529A and R529B labeled SWEEP RATE. In the LINE SYNC position, voltage of the power source frequency is applied to one grid, pin 7, of the V501 multi-vibrator.

4-38. Either the output of the multi-vibrator oscillator or an external sweep voltage applied through the EXTERNAL SWEEP IN post J501, is fed to the grid of amplifier V502. The time constants in this circuit are chosen so as to integrate the rectangular waveform from the multi-vibrator into a triangular saw-tooth waveform. This waveform, or the EXTERNAL SWEEP waveform, is amplified in the second half of V502 and delivered as EXTERNAL SWEEP OUT voltage through the front panel post J503.

4-39. The SWEEP WIDTH control, R536, feeds a controllable amount of saw-tooth voltage into the amplifier V504 whose output appears across the cathode load resistor, R542, of the second section, which is common with the dc amplifier, V505.

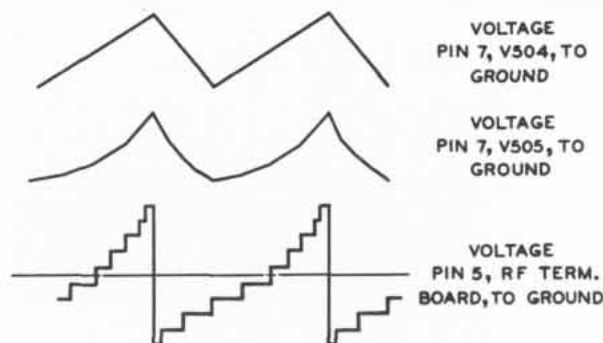

Figure 4-6. Sweep Control Waveforms

#### 4-40. SHAPING CIRCUITS.

4-41. For the reasons mentioned in paragraph 4-26, it is necessary to adjust the waveshape of the saw-tooth current being fed to the yokes, L408 and L409, in order to produce a linear deviation of frequency as a function of the original saw-tooth voltage. This is done by the voltage shaping network in the grid and cathode of V505; the triple diode, V506; and the compensating resistors associated with S501, sections D, E, and F. The bias voltages appearing across the three elements contained in the 6BJ7 tube, V506, are controlled by the five potentiometers R549, R553, R558, R564 and R573, which are selected by the frequency range switch.

4-42. These bias levels determine when each diode cuts into the circuit as the dc voltage on the cathode increases. The amount by which each diode changes the slope of the waveform is determined by the addition of the resistances R548, R552, R557, R563 and R568 in the voltage divider containing R539 from the cathode of V504. Additional control is obtained through the diode CR501 acting on the cathode of V505

4-43. The center-frequency current on each band is adjusted independently for CW and for SWEEP operation by means of five controls each associated with the Range Switch S501. In CW operation, controls R534, R535, R537, R538, and R540, each of which is associated with one of the five frequency bands, are adjusted to produce the fixed value of current through the yoke which establishes the operating point of the saturable reactor.

4-44. In SWEEP operation, the compensating diode V503, in conjunction with the center current resistors R525, R526, R527, R531 and R533, establishes center current for the sweep. The compensating diode V503 is required to maintain the center frequency stable as the line voltage is varied, and is adjusted by means of R510.

**4-45. AUTOMATIC LEVELING.**

4-46. In the RF Unit, the voltage out of the buffer-amplifier, V401, appearing at C406 is monitored by the full-wave crystal diode voltmeter, CR402 and CR403. This voltage is fed by way of Section E on the CW-SWEEP switch S503 to the input of a high-gain DC amplifier, consisting of the four triodes in V507 and V508, which controls the series regulator tube, V509. Tube V509 controls the plate voltage of the RF oscillator, and hence the output level.

4-47. In CW operation, the Automatic Gain Control Amplifier is referenced back to a fixed voltage divider system to provide additional stability of the oscillator circuit.

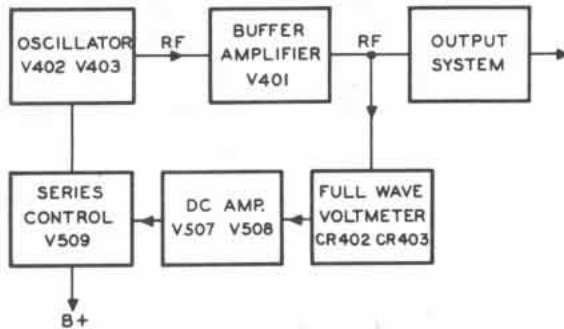

Figure 4-7. Automatic Levelling - Block Diagram

**4-48. RF BLANKING.**

4-49. During the return trace on the oscilloscope, the oscillator is turned off so that a zero-reference base line is established on the display pattern for use in measuring response characteristics. This is done by applying the rectangular wavelshape from the output of the multi-vibrator through C506 to grid number 2 of V508.

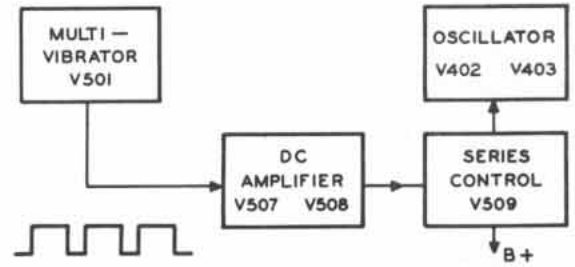

Figure 4-8. RF Blanking - Block Diagram

**4-50. MARKER GENERATOR.**

4-51. A 2.5 Mc crystal, Y201, is used to stabilize the oscillator V201. The signal is fed to the grid of V202 which has plate loads tuned to 2.5 Mc and 0.5 Mc controlled by the adjustable slugs in L202 and L203, respectively.

4-52. The dual triode V204 contains two oscillators; one operating at 0.1 Mc and tuned by L207 with capacitors C226 and C229, the other operating at 0.5 Mc tuned by L208 and C227. These two oscillators operate at sub-harmonic frequencies by tapping the coils into the plate-load circuit of V202, thereby producing sub-synchronous operation.

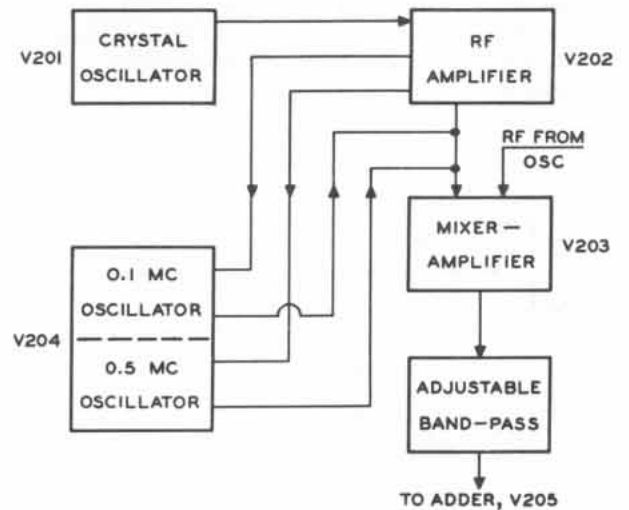

Figure 4-9. Crystal Markers - Block Diagram

4-53. The input to the cathode of V203 contains harmonics of 0.1 Mc, 0.5 Mc and 2.5 Mc. Selection of the desired combination of frequencies is obtained by switching of the power supply to the various oscillators.

4-54. The first section of V203 constitutes a mixer. On its cathode appears a band of harmonics of the crystal-controlled oscillator and on its grid is placed

a sample of the RF voltage delivered at the output of the buffer amplifier through the switch S401. This switch is located inside the RF Unit and is driven by a mechanical linkage which is interlocked with the Crystal Selector Switch on the front panel. When the crystal markers are turned OFF, the coaxial switch is shorted so that no radio frequency voltage is allowed to leak out of the RF Unit.

4-55. The output of the mixer section of V203 is fed into RC networks which control the gain-versus-bandwidth characteristics of the amplifier consisting of the second section of V203. Additional bandwidth control is obtained by means of the resonant circuits in the cathode of the second section of V203 tuned by inductors L209 and L210. Additional control is obtained by means of the series resonant traps tuned by L204 and L205. The purpose of these bandwidth adjustments is to maintain an approximately constant ratio of the passband of the amplifier to the separation of the harmonics being observed, so that the appearance of the birdie markers on the screen will be uniform regardless of frequency separation.

#### 4-56. PIP MARKER GENERATOR.

4-57. A trigger spike is derived from the multi-vibrator tube, V501, and is fed to two separate delay multi-vibrators, V101 and V102, by way of capacitors C103 and C108. These two delay multi-vibrator circuits are identical and are controlled by R107 and R119, labeled PIP MARKER POSITION #1 and #2. These controls are identical in function and may be used interchangeably regardless of the sequential numbering.

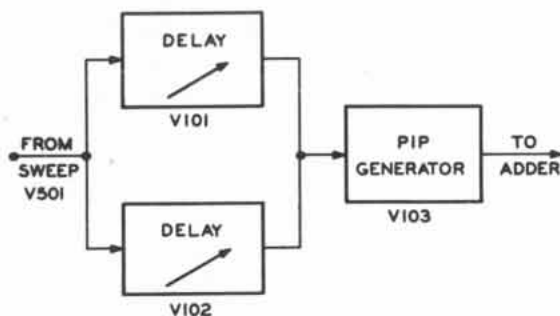

Figure 4-10. Pip Markers - Block Diagram

4-58. The function of the multi-vibrators is to generate two new trigger pulses having adjustable delays with respect to the trigger derived from the multi-vibrator which drives the sweep system. These two trigger pulses are capacitively coupled through C102 and C107 to the diodes CR102 and CR103 into the common plate connection on the actual pip generator tube, V103. This tube produces a narrow spike approximately 50 micro-

seconds wide to the PIP MARKER AMPLITUDE control, R117. The fall time in this circuit has been made sufficiently fast so that it will respond to double pulsing from the two delay multi-vibrators when the separation is greater than the width of the pulse.

4-59. The output of the Pip Marker Generator is fed to the Adder Amplifier, V205, by way of the RC network R230 and C238 to the plate of the tube. The amplitude may be controlled by PIP MARKER AMPLITUDE control R117.

#### 4-60. COMPOSITE SIGNAL AMPLIFIER.

4-61. Pip markers, generated in the Pip Marker Generator, are fed through the AMPLITUDE control, R117, and impressed on the plate of tube V205. The birdie markers, derived from the Birdie Generator and associated switching, are fed to the #1 grid of the pentode section of V205.

4-62. The detected output of the system under test is connected to J203 TEST SIGNAL IN. This signal passes through the TEST SIGNAL IN-AMPLITUDE CONTROL, R234, and drives the grid of the triode section of V205, whose plate is common to the pentode section. The composite signal, thus derived, is fed to the COMPOSITE SIGNAL OUT jack, J201, and to the CALIBRATE jack for use with headphones or an oscilloscope.

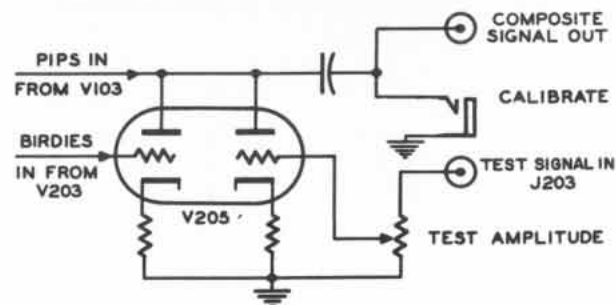

Figure 4-11. Composite Signal Amplifier

#### 4-63. POWER SUPPLY.

4-64. The Power Supply of the Sweep Signal Generator is manufactured for either the Model 240A, 60 cps at 105 to 125 volts, or the Model 240AP, 50 cps at 105 to 125 volts. Operation on any other voltage or frequency will result in serious damage to the instrument.

4-65. All power is fused by the front panel FUSE, F601, which is contained in a replaceable type cartridge mounted on the front panel adjacent to the pilot light. A voltage stabilizer, T602, is connected to:  
(a) a regulated negative supply consisting of the diode rectifier CR601 and the glow regulator type

OA3 tube, V606; (b) the full-wave selenium rectifier circuit consisting of CR602A, B, C and D and the associated filter by way of transformer T603; and (c) the dual-winding filament transformer, T604, whose output is used to feed critical filaments throughout the system. The main power transformer, T601,

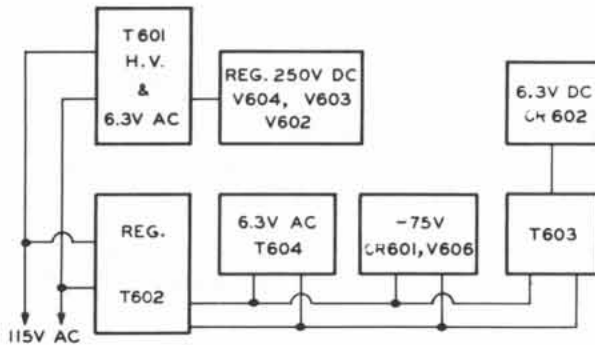

Figure 4-12. Power Supply - Block Diagram

has on it a source of unregulated filaments at 6.3 volts, the high voltage winding used to feed the plates of the high voltage rectifier, V605, and the filaments of V605.

4-66. The filaments of the high-voltage rectifier, V605, are fed through a thermal delay Type 6N030, S602, whose filaments are driven from the unregulated 6.3v supply. This switch, S602 introduces approximately a 30-second delay between the time of application of voltage to the filaments and closing of the contacts to the rectifier, V605, thus delaying the application of the high voltage to all tubes in the circuit. The output of the rectifier, V605, is fed through series regulator tubes V604 and V607 which are controlled in turn by the reference tube and dc amplifiers V602 and V603. The output voltage is controlled by the reference potentiometer, R608.

4-67. Additional fusing on the 250-volt line is contained in the fuse F401. This fuse is included to protect the driving windings of the yoke, L408 and L409. It is located on the terminal board immediately outside of the RF Unit.

Table 5-1. Recommended Test Equipment

Instrument Type	Required Characteristics	Instrument Recommended
Electronic Voltmeter	AC-DC Voltage: to 300 volts Input impedance; dc: 100 megohms Input impedance; ac: >10 megohms Accuracy $\pm 3\%$	-hp- 410C Electronic Voltmeter
Clip-on Milliammeter	Current range: 0 to 50 ma Accuracy $\pm 3\%$	-hp- 428B Clip-on DC Milliammeter
High Frequency Oscilloscope	Vertical Sensitivity: 50 mv/cw Frequency range: to 50 Mc	-hp- 175A Oscilloscope
Signal Generator	Frequency range: 50 Kc to 65 Mc Output: at least 3 volts into 50 w.	-hp- 606A HF Signal Generator
Grid Dip Meter	Frequency range: 2.2 to 120 Mc Accuracy: $\pm 2\%$	Measurements Model 59-STD
Electronic Counter	Frequency range: to 120 Mc	-hp- 5245L Electronic Counter with -hp- 5253B Converter
Crystal Detector	Frequency range: 10 to 120 Mc	-hp- 423A Crystal Detector
Power Meter	Power measurement range: to 10 mw Accuracy: $\pm 3\%$	-hp- 431B Power Meter with -hp- 478A Thermistor Mount

Table 5-2. Component Identification

Chassis	Reference Designation Series
Pip Chassis	100's
Marker Chassis	200's
Audio Chassis	300's
RF Limit and Meter	400's
Sweep Chassis	500's
Power Supply	600's



## SECTION V MAINTENANCE

### 5-1. INTRODUCTION.

5-2. This section provides maintenance and service information for the Model 240A Sweep Signal Generator. Included are a table of recommended test equipment, troubleshooting procedures, and repair and adjustment procedures.

### 5-3. TEST EQUIPMENT.

5-4. Recommended test equipment for troubleshooting and repair is listed in Table 5-1. Other test instruments may be used if their specifications equal or exceed the required characteristics.

### 5-5. COMPONENT IDENTIFICATION.

5-6. Schematic reference designations of subassemblies are assigned by blocks in accordance with Table 5-2. Figure 6-1 shows the physical location of the subassemblies within the 240A.

**WARNING:** An idle heater in the RF Unit subassembly is powered when the line switch is in the off position. Power line voltages are exposed by removing covers. Exercise caution during troubleshooting and repair.

### 5-6. ADJUSTMENTS.

5-8. Specifications of frequency accuracy are met after a 4-hour in-cabinet warmup. After repair work is completed, the 240A should be allowed to stabilize with the top cabinet in place, and the instrument in its normal vertical position. The frequency adjustments are located behind the front panel, underneath the sweep chassis, so adjustments can be made with 5 inches of the instrument hanging over the work bench front.

5-9. The use of ferrite forms for the oscillator inductors requires that certain precautions be taken during calibration.

a. When switching from CW to SWEEP operation turn the SWEEP WIDTH control fully clockwise and then fully counter-clockwise, repeating a few times. This will remove the effects of a change in ferrite bias.

b. When switching from SWEEP to CW, or changing frequency ranges, allow 5 minutes for stabilization.

5-10. Procedures for checking and adjusting the 240A are provided in paragraphs 5-8 through 5-28. When making a thorough check of the instrument it is recommended that procedures be performed in the order presented. Voltages and waveforms are made from point indicated to chassis ground.

**VARIABLE LINE VOLTAGE.** During the checks and adjustments the 240A should be connected to a power source through a variable voltage device so that line voltage may be varied  $\pm 10\%$  from 115 V to assure proper operation under various line conditions.

### 5-11. POWER SUPPLY.

a. Apply 115 V at the frequency indicated on the voltage plate above the power receptacle.

b. Allow 1/2 hour warmup and check for 250 VDC at TP1 (V604 pin 6). If the voltage is between 245 and 255 volts, do not make an adjustment until frequency calibration has been checked. (The B supply voltage may be used to make all-band corrections of frequency calibration if the error is less than approximately 3%.)

c. If a complete alignment is to be made, adjust R602 for 250 VDC at TP1.

d. Check for -75 VDC  $\pm 3$  V at TP2 (negative terminal of C603).

e. Set front panel controls as follows:

CRYSTAL MARKER MC . . . . .	.1
CRYSTAL MARKER AMPLITUDE . . . . .	max
PIP MARKER AMPLITUDE . . . . .	max
FREQUENCY RANGE MC . . . . .	75 - 120
CENTER FREQ. . . . .	90
CW- SWEEP . . . . .	SWEEP
AM . . . . .	ON

f. Measure ripple and regulation at TP1 with changing line voltage:

Ripple limit: 8 mv rms max.

Regulation limit:  $\pm 0.4$  V max.

g. Measure dc current through R602 with clip-on milliammeter. Adjust R601 for  $41 \pm 1$  ma.

5-12. MARKER AMPLIFIER TRAPS.

- a. Power to 240A is removed.
- b. Set front panel CRYSTAL MARKER MC to .1.
- c. Connect oscilloscope across L210.
- d. Remove V203 and inject a 500 Kc signal through a 2.2 K resistor to V203, pin 8.
- e. Tune L209 for minimum oscilloscope deflection.
- f. Inject a 500 Kc signal through a 2.2 K resistor to V203, pin 6. Connect oscilloscope to V203, pin 6.
- g. Adjust L204 for minimum oscilloscope deflection.
- h. Change signal generator frequency to 100 Kc and adjust L205 for minimum oscilloscope deflection.

5-13. MARKER OSCILLATORS.

- a. Apply power to 240A. Remove V605 (5U4GB).
- b. Connect oscilloscope probe to junction of L202 and L203.
- c. Inject 500 Kc signal at V202, pin 5.
- d. Tune L203 for maximum oscilloscope deflection.
- e. Remove connections; re-insert V605.
- f. Set CRYSTAL MARKER MC to OFF. Adjust L202 for 2.5 Mc as indicated on grid-dip meter.
- g. Set front panel controls as follows:

PIP MARKER AMPLITUDE . . . . .	MIN
FREQ RANGE MC . . . . .	35 - 75
CENTER FREQUENCY . . . . .	50
CW - SWEEP . . . . .	SWEEP
SWEEP SELECTOR . . . . .	INT
CRYSTAL MARKER MC . . . . .	2.5

- h. Connect SWEEP OUT terminal to oscilloscope horizontal input and adjust controls for about 11 cm of sweep.
- i. Connect COMPOSITE SIGNAL OUT to oscilloscope vertical input. Adjust 240A CENTER FREQ and SWEEP WIDTH controls for two "birdies" 10 cm apart on the trace.
- j. Set CRYSTAL MARKER-MC to 0.5. Adjust L208 for 4 "birdies" between the two set up in step i. Increase CRYSTAL MARKER AMPLITUDE to identify all markers - there may be some variation in "birdie" amplitude. Find the center of the

lock-in range of L208. Check at low line voltage.

- k. Reduce SWEEP WIDTH to place two 0.5 Mc "birdies" 10 cm apart.
- l. Change CRYSTAL MARKER MC to .1 and adjust L207 for 4 "birdies" between the two setup in step k. Again, tune L207 for the center of the lock-in range and check at low line voltage.
- m. After adjustments are made, be sure to tighten lock nuts. If birdies are unstable or baseline noise appears, check power supply regulation.

5-14. PIP MARKERS.

- a. Apply power to 240A. Allow 1/2 hour warmup.
- b. Set front panel controls as follows:

PIP MARKER	
AMPLITUDE . . . . .	clockwise
PIP MARKER	
POSITION 1 & 2 . . . . .	30° from clockwise
SWEEP SELECTOR . . . . .	INT
SWEEP RATE . . . . .	20~

- c. Connect oscilloscope vertical input to COMPOSITE SIGNAL OUT; horizontal input to SWEEP OUT.
- d. Adjust sweep width to less than 10 cm.
- e. Rotate R122 to counter-clockwise stop. Slowly turn clockwise until oscillations appear on oscilloscope trace. Continue turning until oscillations cease and two clearly defined pips appear.
- f. Vary PIP MARKER POSITION 1 and 2 controls. Pips should cross each other and have sufficient range to go to the right - side trace limit at the 20 sweep rate. It is normal for pips to appear on the baseline when the pip marker position is adjusted past the right extreme of sweep width.

5-15. RF OUTPUT AND AGC

- a. Turn RF LEVEL VERNIER control to maximum clockwise with AM control ON.
- b. The RF LEVEL METER should indicate more than 0.3 V with the CW-SWEEP selector in the SWEEP position.
- c. The RF LEVEL METER should indicate more than 0.1 V with the CW-SWEEP selector in the CW position.

5-16. If the conditions of 5-15 b and c are not met, check for weak oscillator or buffer amplifier tubes (V401, 402; and 403). If the condition of 5-15c is not met, check modulator diode CR404.

5-17. AGC ADJUSTMENT

a. Measure AGC voltage at RF Unit terminal board, pin 8, with SWEEP WIDTH at maximum. Voltage should be 3.8 to 4.0 V, constant  $\pm 2\%$  except above 100 Mc where it may be  $\pm 3\%$ . Poor flatness usually indicates defective CR402 and CR403 diodes.

b. If AGC voltage is not between 3.8 and 4 V, adjust R574 and R560 while monitoring oscillator B+ (RF Unit terminal board, pin 4). Proper voltage should be obtained with oscillator voltage between 60 and 160 V. If not, oscillator tubes are weak or CR402 and CR403 are defective.

5-18. PRELIMINARY FREQUENCY ADJUSTMENT.

5-19. Check the frequency accuracy at a few points on all bands to determine if there is a trend to the errors. Either use the internal crystal markers and headphones connected to the CALIBRATE jack, or a frequency counter. Sweep width should be set to minimum. Adjusting the +250 V regulated supply within  $\pm 5$  volts may bring all frequency ranges within the 1% accuracy limits. If a power supply adjustment will not bring calibration within limits, a complete adjustment is necessary.

5-20. CW FREQUENCY CALIBRATION.

a. Allow 4-hour warmup with cabinet in place and bottom cover removed. Slide 240A over edge of test bench to gain access to calibration controls.

b. Adjust power supply as in Paragraph 5-11c.

c. Use frequency counter or internal markers for determining frequency. If internal markers are to be used, read Paragraph 5-40.

d. Set front panel controls as follows:

FREQUENCY RANGE MC . . . . . 4.5 - 9  
CENTER FREQUENCY . . . . . 4.5  
CW - SWEEP . . . . . CW

e. Adjust calibrating controls for each frequency band as indicated in Table 5-3. Allow 5 minutes

Table 5-3. CW Frequency Calibration

Frequency Range (MC)	Calibration Control
4.5 - 9	R540
9 - 18	R538
18 - 35	R537
35 - 75	R535
75 - 120	R534

for stabilization after changing bands. Clockwise rotation of controls increases output frequency; use insulated screwdriver shank to prevent grounding of circuits. Compromise adjustment on each band for best overall calibration

5-21. SWEEP FREQUENCY CALIBRATION

a. Set front panel controls as follows:

FREQUENCY RANGE MC . . . . . 4.5 - 9  
CENTER FREQ . . . . . 4.5  
SWEEP WIDTH . . . . . MIN  
CW - SWEEP . . . . . SWEEP  
SWEEP SELECTOR . . . . . INT  
AM . . . . . OFF

b. Use frequency counter to measure output frequency or internal crystal frequencies.

c. Turn SWEEP WIDTH TO MAX and then to MIN a few times, leaving control at MIN.

d. Adjust center frequency calibration as indicated in Table 5-4. After changing ranges, turn SWEEP SELECTOR TO INT, and adjust SWEEP WIDTH TO MAX a few times. Return SWEEP SELECTOR to EXT and wait 5 minutes before changing calibration.

Table 5-4. Center Frequency Calibration

Frequency Range (MC)	Calibration Control
4.5 - 9	R533
9 - 18	R531
18 - 35	R527
35 - 75	R526
75 - 120	R525

e. Adjust R510 for minimum center frequency change with line voltage. This is done at or near minimum sweep width. Locate a birdie at low line voltage and readjust R510 at high line voltage to return the birdie to the same position.

5-22. Sweep center frequency calibration is dependent upon sweep linearity adjustments and may have to be corrected slightly when making sweep linearity adjustments.

5-23. SWEEP LINEARITY.

5-24. BAND 5 - 75 -120 MC. Linearity is adjusted at 75 Mc and will be within limits at higher center frequencies.

**IMPORTANT:** Sweep linearity is specified within a certain sweep width range. It is possible to sweep well beyond the limits of linearity over most of the range of the 240A. When checking linearity, always adjust the sweep width for the maximum specified limits of  $\pm 30\%$  of center frequency below 50 Mc and  $\pm 15$  Mc above 50 Mc.

a. Set front panel controls as follows:

FREQ RANGE MC . . . . . 75 - 120  
 CENTER FREQUENCY . . . . . 75  
 PIP MARKER AMPLITUDE . . . . . MIN  
 CRYSTAL MARKER  
   AMPLITUDE. . . . . MAX  
 CRYSTAL MARKER MC . . . . . 2.5  
 AM . . . . . OFF  
 SWEEP SELECTOR . . . . . INT LINE SYNC  
 SWEEP RATE . . . . . 60~  
 CW - SWEEP . . . . . SWEEP

b. Connect RF OUTPUT to a crystal detector input; crystal detector output to TEST IN. Connect oscilloscope vertical input to COMPOSITE SIGNAL OUT; horizontal input to SWEEP OUT.

c. Adjust R532 for maximum sweep width.

d. Adjust oscilloscope presentation as in Figure 5-1. Increase SWEEP WIDTH control so there are six - 2.5 Mc birdies on each side of center sweep and check linearity for limits shown in Figure 5-2.

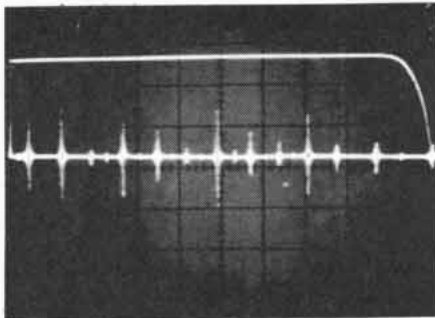

Figure 5-1. Band 5 Linearity Presentation

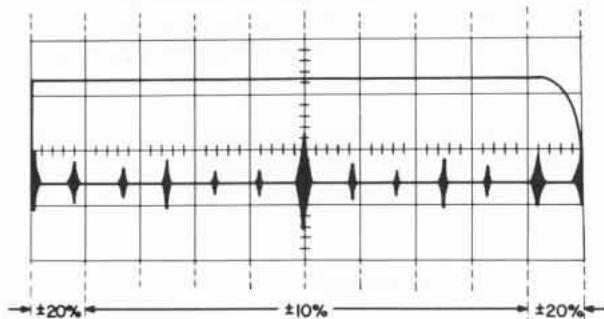

Figure 5-2. Linearity Limits

e. If linearity requires adjustment, it will be necessary to adjust a number of controls to return to proper performance:

- (1) Any shaping adjustment will require readjusting R525 center frequency control. Temporarily reduce sweep width and adjust R525 so the 75 Mc birdie lies in the center of the sweep.
- (2) Any adjustments will require a change of SWEEP WIDTH so that six markers are seen on each side of center.
- (3) Shaping adjustments R599, R558 and R573 are adjusted for optimum linearity. The effects of the controls are as follows:

R573 affects the first 20% of the sweep.  
 R549 affects the first 40% of the sweep.  
 R599 affects the first 60% of the sweep.

f. The most efficient way to adjust linearity is to first correct for gross nonlinearity and then correct center frequency. Adjust sweep width to  $\pm 15$  Mc and repeat. If any ambiguity in markers appears, couple a calibrated signal generator into the crystal mixer input and use the developed birdie to identify the markers.

g. When adjustments are complete, turn SWEEP WIDTH to max and readjust R532 so that only slightly more than  $\pm 15$  Mc is viewed on the oscilloscope pattern.

h. Check linearity at high end of 75 - 120 Mc range and compromise adjustments if necessary.

i. Adjust R511 so retrace of sweep occurs at very end of horizontal trace. This will usually be at or near the clockwise stop.

5-25. BAND 4, 35 - 75 MC.

a. Set FREQ RANGE MC to 35 - 75 and other controls as in Paragraph 5-24a.

b. Connect RF OUTPUT to crystal detector input; crystal detector output to TEST IN. Connect oscilloscope vertical input to COMPOSITE SIGNAL OUT; horizontal input to SWEEP OUT.

c. Adjust SWEEP WIDTH control for six birdies on either side of center.

d. Adjust linearity controls R553 and R564: R553 adjusts the first 20% of the sweep; R564 adjusts the first 50% of the sweep.

e. Adjustment requires the manipulation of a number of controls: R553 and R544 shaping adjustments, R526 sweep center frequency and SWEEP WIDTH, since there is interaction caused by all the controls.

5-26. **LOW BANDS 1-3, 4.5-35 Mc.**  
A check should be made at various points on the three low bands. If non-linearity is excessive, some compromise must be made in the 35-75 Mc band adjustments. Before compromising, however, read Paragraph 5-40.

5-27. **RF LEVEL METER.**

- a. Set front panel controls as follows:  
  
RF LEVEL FULL SCALE (CW) - .1 V  
CW - SWEEP . . . . . CW
- b. Connect power meter to RF OUTPUT connector. Adjust RF LEVEL VERNIER for 0.2 mw output at any frequency above 10 Mc.
- c. Adjust R541 for full scale on RF LEVEL meter red scale (10).
- d. Change CW - SWEEP control to SWEEP; SWEEP SELECTOR to EXT.
- e. Adjust RF LEVEL VERNIER for 1.8 mw output.
- f. Adjust R445 for full scale on RF LEVEL METER black scale (30).

5-28. **AM CALIBRATION**

- a. Turn R539 to counterclockwise stop.
- b. Turn AM control ON and adjust R307 for 2.0 V RMS at V301, pin 6.
- c. Connect high frequency oscilloscope to RF OUTPUT and adjust R304 for 30% modulation.

5-29. **TROUBLE SHOOTING AND REPAIR.**

5-30. **TUBE REPLACEMENT.**

5-31. Replacement of all tubes outside the RF Unit requires a check of the associated circuit adjustment. Oscillator tubes in the RF Unit, V402 and V403, have pigtail leads that are soldered in place. Lead arrangement should be as shown in Figure 5-3.

5-32. **YOKE AND RANGE SWITCH REPAIR.**

5-33. Inspection of the RF range switch and T401 through T405 will require disassembly of the range switch assembly. To avoid the necessity of critical

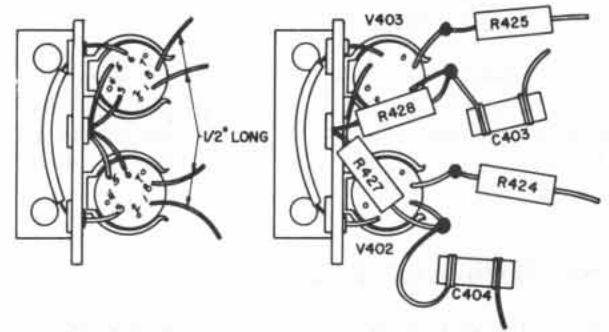

Figure 5-3. Oscillator Tube Connections

mechanical alignment, remove the three screws marked "A" in Figure 6-9. This will allow the switch wafers, phenolic board and yoke assembly (L408 and L409) to be removed easily for service.

5-34. **TROUBLE SHOOTING CHART.**

5-35. The Trouble Shooting Chart (Table 5-5) lists symptoms that could possibly develop in the instrument and details faults, probable causes of these faults, remedies, and procedures for correcting these conditions. It is suggested that this chart be used as a first step in analyzing trouble since considerable time and effort associated with unnecessary readjustment or alignment can therefore be avoided.

5-36. **CIRCUIT VOLTAGES.**

5-37. Table 5-6 lists the normal operating voltages at tube sockets, interconnections and at the RF Unit terminal board shown in Figure 5-4. Terminal board numbers are identified in Figure 5-4 and on the RF Unit schematic with a circle.

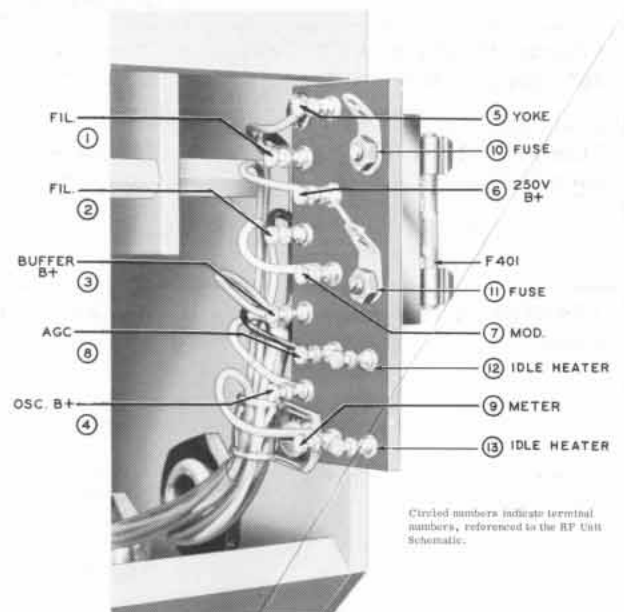

Circled numbers indicate terminal numbers, referenced to the RF Unit Schematic.

Figure 5-4. RF Unit Terminal Board.

5-38. WAVEFORMS.

5-39. Waveforms of 240A circuit operation in the sweep mode are illustrated adjacent to the schematic of the associated circuits. Waveform test points are identified on the schematics with a number inside a triangle; e.g.,  $\triangle 3$ .

5-40. MARKER AMBIGUITY.

5-41. Because of the extremely wide sweep range and the possibility of gross misadjustment of linearity particularly on the 35-75 and 75-120 Mc ranges, it is possible to interpret the marker birdies incorrectly. If any doubt exists as to marker interpretation, make an equipment connection as shown in Figure 5-5. By injecting signals from a grid-dip oscillator or exter-

nal signal generator that is accurately calibrated, it is possible to identify birdies accurately. This technique is particularly useful when calibrating the high frequency ranges, where adjustment range exceeds the largest marker interval of 2.5 Mc.

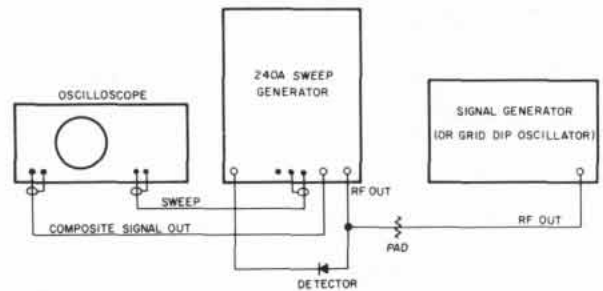

Figure 5-5. Setup for Pip Identification

Table 5-5. Trouble-Shooting Chart

Symptom	Possible Cause	Correction
With the equipment connected to a suitable 115-volt source and Power Switch "ON", pilot light does not light.	Fuse defective.	Replace fuse F601.
	Pilot light defective.	Replace pilot light DS601.
	Primary winding or filament secondary winding of power transformer open.	Check continuity of transformer T601 and replace if defective.
Vacuum tube filaments do not light.	Defective vacuum tube.	Check vacuum tube and replace if defective.
	Primary winding or secondary windings of filament transformer open.	Check continuity of transformer T603 and/or T604.
	Defective voltage stabilizer.	Check continuity of T602.
Vacuum tube filaments of V202, 203, and 205 do not light.	Defective selenium rectifier or capacitor.	Check rectifier bridge CR602 and capacitor C605 and replace if defective.
Fuse F601 blows repeatedly after power is applied.	Vacuum tube rectifier, filter capacitors, power transformer or voltage stabilizer defective.	Remove rectifier V605. If fuse does not blow, check C601 and C602 for possible shorts. If normal, check V605. If normal, check continuity of T601 and T602.
Filaments light but no plate voltage.	Vacuum tube rectifier defective.	Check V605 and replace if defective.
	Filter choke defective.	Check continuity of L601 and replace if defective.
	Filter capacitor defective.	Check C601 and C602 for possible shorts and replace if defective.
No -75 DC voltage.	Defective silicon diode.	Check CR601 and replace if defective.
	Defective capacitors.	Check C603 and C604 for possible shorts.
	Defective filter choke.	Check L602.

Table 5-5. Trouble-Shooting Chart (Cont'd)

Symptom	Possible Cause	Correction
Birdie and pip markers missing from display.	Defective adder stage.	Check V205 and replace if defective. Check connections to Composite Signal Out jack J201. Check C235 for possible open.
No audible signal from Calibrate jack.	Defective connection.	Check connection to Calibrate jack J202.
Birdie markers missing from display.	Defective RF sample switch linkage.	Check mechanical linkage from Marker Selector switch S201 to RF sample switch S401.
With Crystal Marker Selector switch on, .5 Mc oscillations of large amplitude cover entire display.	Poor lock-in.	Adjust choke L208.
Same as above on .1 position.	Poor lock-in.	Adjust choke L207.
No pip marker.	Defective pipe marker multi-vibrator.	Check display at pin 1 of V103. If pips are present, check V103. If tube is good, check C111 for open and check for open connection to adder stage.
	No signal from sweep multi-vibrator	Check connections between multi-vibrator, V501, and pip chassis.
One Pip Marker missing from display.	Defective pip marker multi-vibrator.	Determine tube involved by operating Pip Marker Position Controls. Check tube involved, V101 or V102. and replace if defective.
No sweep voltage.	Sweep multivibrator defective.	Check V501 and replace if defective.
	Shorted capacitor .	Check C513 and C514 and replace if defective.
Excessive sweep voltage.	Open capacitor.	Check C513 or C514 for possible open position.
No audio modulation.	Defective audio oscillator.	Check V301 and replace if defective.
	Defective modulator	Check CR404 diode.
Fuse F401 blows repeatedly.	Excessive yoke current.	Check yoke assembly - L408-409 for possible shorts.
Low RF output	Defective buffer amplifier.	Check V401 and replace if defective.

Table 5-6. Voltage Chart

SOCKET	DESCRIPTION	PIN NUMBER									
		1	2	3	4	5	6	7	8	9	10
V101	12AU7A	∇14	20	20	0	0	220	0	20	6.3 ac	-
V102	12AU7A	∇14	20	20	0	0	220	0	20	6.3 ac	-
V103	12AU7A	∇15	0	20	0	0	∇16	18	20	6.3 ac	-
V201	6AU6A	-17	0	0	6.3 ac	250	122	.04	-	-	-
V202	6AK5	-3.3	0	6.3	0	220	155	0	-	-	-
V203	12AX7A	200	-1.3	∇11	6.3	6.3	175	-.22	.25	0	-
V204	12AU7A	230	-70	12.3	6.3 ac	6.3 ac	235	-138	0	0	-
V205	6U8	94	0	95	0	6.3	∇12	2.8	2.5	0	-
V301#	12AU7A	95	0	3.3	0	0	200	0	7	6.3 ac	-
V401	6BK7A	125	2.6	0	0	6.3 ac	125	0	0	NC	-
##		120	0	0	0	6.3 ac	120	0	0	NC	-
V402	5718	-4.2	NC	6.3 ac	NC	0	0	NC	110	-	-
##		-5.8	NC	6.3 ac	NC	0	0	NC	155	-	-
V403	5718	-4.2	NC	0	NC	0	6.3 ac	NC	110	-	-
##		-5.8	NC	0	NC	0	6.3 ac	NC	155	-	-
V501	12AT7	150	-23	0	6.3 ac	6.3 ac	∇3	∇4	0	0	-
V502	12AX7A	∇6	-.92	0	6.3 ac	6.3 ac	250	90	11.2	0	-
V503	6AL5	-17	-18	0	6.3 ac	-17	NC	-17	-	-	-
V504	12AU7A	124	0	5.5	6.3 ac	6.3 ac	250	-17	-2.8	0	-
V505	6AQ5	∇8	27	0	6.3 ac	∇9	250	11	-	-	-
V506	6BJ7	11	-8.5	NC	6.3 ac	0	-3.2	11	1	11	-
V507	12AX7A	250	2.6	4.2	6.3 ac	6.3 ac	45	3.8	4.3	0	-
V508	12AX7A	82	-90	-68	0	0	82	-11.5	0	6.3 ac	-
V509	6AQ5	82	∇10	0	0	250	250	82	-	-	-
V602	5651	NC	NC	NC	NC	85	NC	0	-	-	-
V603	12AX7A	200	125	125	0	0	125	58	58	6.3 ac	-
V604	6AS7G	200	380	250	200	380	250	6.3 ac	0	-	-
V605	5U4G	NC	36 ac	NC	400 ac	NC	400 ac	NC	420	-	-
V606	OA3	NC	-75	NC	NC	0	NC	NC	NC	-	-
V607	6AS7G	200	380	250	200	380	250	6.3 ac	0	-	-

Multiple Connectors

J601	to Sweep	6.3 ac	0	NC	115 ac	165	250	-75	0	0	0
J602	to Marker	6.3 ac	0	0	250	6.3	0	-	-	-	-
J603	to Audio	0	6.3 ac	250	0	-	-	-	-	-	-
J604	to Panel	0	64 ac	6.3 ac	64 ac	-	-	-	-	-	-

RF Terminal Board

Sweep condition	6.3 ac	0	165	∇10	220	250	3.2	2.5	-1.4	-
CW condition	6.3 ac	0	165	160	230	250	1.0	3.2	-1.4	-

NOTES

1. Unless otherwise noted all measurements are made with the 240A in the "sweep" condition.
2. # Voltages shown in CW condition only.
3. ## Voltages shown in CW condition for above tube.
4. ∇3 Refers to test points with oscilloscope waveforms shown on schematics.



## SECTION VI REPLACEABLE PARTS

### 6-1. INTRODUCTION.

6-2. This section contains information for ordering replacement parts. The Reference Designation Index lists parts in alpha-numerical order of their reference designations and indicates the description and -hp- stock number of each part. Miscellaneous mechanical parts are listed in -hp- stock number order at the end of the Reference Designation Index.

### 6-3 ORDERING INFORMATION.

6-4. To obtain replacement parts, address order or inquiry to your local Hewlett-Packard sales and

service office (see lists at rear of this manual). Identify parts by Hewlett-Packard stock number.

6-5. To obtain a part not listed, include:

- a. Instrument model number.
- b. Instrument serial number
- c. Description of part
- d. Function and location of part.

#### REFERENCE DESIGNATORS

A = assembly	E = misc electronic part	MP = mechanical part	TB = terminal board
B = motor	F = fuse	P = plug	TP = test point
C = capacitor	FL = filter	Q = transistor	V = vacuum tube, neon bulb, photocell, etc.
CP = coupling	J = jack	R = resistor	W = cable
CR = diode	K = relay	RT = thermistor	X = socket
DL = delay line	L = inductor	S = switch	Y = crystal
DS = device signaling (lamp)	M = meter	T = transformer	

#### ABBREVIATIONS

A = ampere	GE = germanium	N = nano ( $10^{-9}$ )	RMS = root-mean-square
A. F. C = automatic frequency control	GL = glass	N/C = normally closed	ROT = rotary
AMPL = amplifier	GMV = guaranteed minimum value	NE = neon	S-II = slow-blow
B. F. O = beat frequency oscillator	GRD = ground(ed)	Ni PL = nickel plate	SCR = screw
BE CU = beryllium copper	H = henries	N/O = normally open	SE = selenium
BE CU = binder head	HEX = hexagonal	NPO = negative positive zero	SECT = section(s)
BP = bandpass	HG = mercury	(zero temperature coefficient)	SEMICON = semiconductor
BRS = brass	HR = hour(s)	NHR = not recommended for field replacement	SI = silicon
BWO = backward wave oscillator	IF = intermediate freq	NSR = not separately replaceable	SIL = silver
CCW = counter-clockwise	IMPG = impregnated	OB = order by description	SL = slide
CER = ceramic	INCD = incandescent	OH = oval head	SPL = special
CMO = cabinet mount only	INCL = include(s)	OX = oxide	SST = stainless steel
COEF = coefficient	INS = insulation(ed)	P = peak	SR = split ring
COM = common	INT = internal	PC = printed circuit	STL = steel
COMP = composition	K = kilo = 1000	PF = picofarads = $10^{-12}$ farads	TA = tantalum
CONN = connector	LIN = linear taper	PH BRZ = phosphor bronze	TD = time delay
CP = cadmium plate	LX WASH = lock washer	PHL = Phillips	TI = titanium
CRT = Cathode-ray tube	LOG = logarithmic taper	PV = peak universe voltage	TGL = toggle
CW = clockwise	LPF = low pass filter	P/O = part of	TOL = tolerance
DEPC = deposited carbon	M = milli = $10^{-3}$	POLY = polystyrene	TRIM = trimmer
DR = drive	MEG = meg = $10^6$	PORC = porcelain	TWT = traveling wave tube
ELECT = electrolytic	METFLM = metal film	POS = position(s)	U = micro = $10^{-6}$
ENCAP = encapsulated	MET OX = metal oxide	POT = potentiometer	VAC = vacuum
EXT = external	MFR = manufacturer	PP = peak-to-peak	VAR = variable
F = farads	MINAT = miniature	PT = point	VDCW = dc working volts
FH = flat head	MOM = momentary	RECT = rectifier	W = watts
FIL H = fillister head	MTG = mounting	RF = radio frequency	W/ = with
FXD = fixed	MY = "nylon"	RH = round head	W/O = without
		RMO = rack mount only	WW = wirewound

Table 6-1. Reference Designation Index

Reference Designation	Stock No.	Description	Note
<b>PIP CHASSIS</b>			
C101	0180-0250	C: fxd, elect, 3 x 10 $\mu$ f, 450 VDCW	
C102,103	0160-0855	C: fxd, cer, 24 pf, 2%, 500 VDCW	
C104	0160-0873	C: fxd, paper, .033 $\mu$ f, 20%, 400 VDCW	
C105,C106	0160-0854	C: fxd, cer, 22 pf, 2-1/2%, 500 VDCW	
C107,C108	0160-0855	C: fxd, cer, 24 pf, 2%, 500 VDCW	
C109	0160-0873	C: fxd, paper, .033 $\mu$ f, 20%, 400 VDCW	
C110	0160-0847	C: fxd, mica, 68 pf, 5%, 500 VDCW	
C111	0160-0879	C: fxd, mylar, 0.25 $\mu$ f, 20%, 400 VDCW	
CR101-104	1910-0031	Diode: germanium, 1N34A	
R101	0689-1525	R: fxd, comp, 1500 ohm, 5%, 1W	
R102	0686-6835	R: fxd, comp, 68 K ohm, 5%, 1/2W	
R103	0689-3335	R: fxd, comp, 33 K ohm, 5%, 1W	
R104	0692-1035	R: fxd, comp, 10 K ohm, 5%, 2W	
R105	0689-2225	R: fxd, comp, 2200 ohm, 5%, 1W	
R106	0686-3335	R: fxd, comp, 33 K ohm, 5%, 1/2W	
R107	2100-0934	R: var, 1 megohm, 20%, 1/4W	
R108, 109	0686-2225	R: fxd, comp, 2200 ohm, 5%, 1/2W	
R110	0686-6835	R: fxd, comp, 68 K ohm, 5%, 1/2W	
R111	0689-3335	R: fxd, comp, 33 K ohm, 5%, 1W	
R112	0692-1035	R: fxd, comp, 10 K ohm, 5%, 2W	
R113	0686-4735	R: fxd, comp, 47 K ohm, 5%, 1/2W	
R114	0692-1535	R: fxd, comp, 15 K ohm, 5%, 2W	
R115	0686-3335	R: fxd, comp, 33 K ohm, 5%, 1/2W	
R116	0686-1035	R: fxd, comp, 10 K ohm, 5%, 1/2W	
R117	2100-0932	R: var, 50 K ohm, 20%, 1/3W	
R118	0686-2225	R: fxd, comp, 2200 ohm, 5%, 1/2W	
R119	2100-0934	R: var, 1 megohm, 20%, 1/4W	
R120	0686-4745	R: fxd, comp, 470 K ohm, 5%, 1/2W	
R121	0686-2225	R: fxd, comp, 2200 ohm, 5%, 1/2W	
R122	2100-0885	R: var, 5 K ohm, 20%, 1/2W	
V101-103	1932-0029	Electron Tube: 12AU7	
<b>MARKER CHASSIS</b>			
C201	0180-0268	C: fxd, elect, 20-20 $\mu$ f, 450 VDCW	
C202		Not Assigned	
C203,204	0160-0705	C: fxd, cer, 33 pf, 2%, 600 VDCW	
C205	0160-0488	C: fxd, cer, 10 pf, 2%, 500 VDCW	
C206	0160-0451	C: fxd, paper, 0.25 $\mu$ f, 400 VDCW	

Table 6-1. Reference Designation Index (Cont'd)

Reference Designation	Stock No.	Description	Note
C207	0160-0705	C: fxd, cer, 33 pf, 2%, 600 VDCW	
C208	0160-0849	C: fxd, mica, 240 pf, 5%, 500 VDCW	
C209	0160-0826	C: fxd, cer, 15 pf, 2%, 500 VDCW	
C210	0160-0246	C: fxd, mica, 3300 pf, 5%, 500 VDCW	
C211	0121-0083	C: var, 1-12 pf, glass, 600 VDCW	
C212, 213, 214	0160-0992	C: fxd, cer, 0.01 $\mu$ f, GMV, 450 VDCW	
C215	0160-0849	C: fxd, mica, 240 pf, 5%, 500 VDCW	
C216	0160-0710	C: fxd, mylar, 0.01 $\mu$ f, 10%, 600 VDCW	
C217	0160-0498	C: fxd, mica, 150 pf, 5%, 500 VDCW	
C218	0160-0789	C: fxd, mica, 100 pf, 5%, 500 VDCW	
C219, 220	0160-0872	C: fxd, mica, 50 pf, 5%, 500 VDCW	
C221	0160-0498	C: fxd, mica, 150 pf, 5%, 500 VDCW	
C222, 223	0160-0849	C: fxd, mica, 240 pf, 5%, 500 VDCW	
C224	0160-0451	C: fxd, paper, 0.25 $\mu$ f, 400 VDCW	
C225		Not Assigned	
C226	0160-0705	C: fxd, cer, 33 pf, 2%, 600 VDCW	
C227	0160-0892	C: fxd, cer, 33 pf, 2%, N080	
C228	0160-0810	C: fxd, mica, 200 pf, 5%, 500 VDCW	
C229	0160-0455	C: fxd, cer, 18 pf, 2%, 600 VDCW	
C230		Not Assigned	
C231	0140-0041	C: fxd, mica, 100 pf, 5%, 500 VDCW	
C232, 233	0160-0705	C: fxd, cer, 33 pf, 2%, 600 VDCW	
C234	0140-0018	C: fxd, mica, 1000 pf, 5%, 500 VDCW	
C235	0160-0833	C: fxd, mylar, 0.5 $\mu$ f, 20%, 400 VDCW	
C236	0160-0849	C: fxd, mica, 240 pf, 5%, 500 VDCW	
C237, 238	0160-0856	C: fxd, cer, 50 pf, 2-1/2%, 600 VDCW	
C239	0160-0874	C: fxd, mylar, 1.0 $\mu$ f, 10%, 400 VDCW	
C240, 241	0160-0992	C: fxd, cer, 0.01 $\mu$ f, GMV, 450 VDCW	
C242	0160-0482	C: fxd, cer, 5 pf, $\pm$ .25 pf, 500 VDCW	
J201	1250-0075	Connector: BNC, UG 291/U	
J202	1251-0205	Jack: Open Circuit	
J203	1250-0074	Connector: BNC, UG 290/U	
L201	5080-1701	Choke, RF, 50 $\mu$ h	
L202	00240-80017	Inductor, var	
L203	00240-80018	Inductor, var	
L204	00240-80016	Inductor, var	
L205	00240-80022	Inductor, var	
L206	9140-0228	Choke, RF, 100 $\mu$ h	
L207	00240-80019	Inductor, var	
L208	00240-80020	Inductor, var	
L209	00240-80021	Inductor, var	
L210	00240-80023	Inductor, fxd	

Table 6-1. Reference Designation Index (Cont'd)

Reference Designation	Stock No.	Description	Note
L211	5080-1701	Choke, RF, 50 $\mu$ h	
P201	1250-0070	Connector: BNC,UG 260/U	
P202	1251-0407	Plug: 6 contact, male	
R201	0686-4725	R: fxd, comp, 4700 ohm, 5%, 1/2W	
R202	0686-1025	R: fxd, comp, 1000 ohm, 5%, 1/2W	
R203, 204	0686-2235	R: fxd, comp, 22 K ohm, 5%, 1/2W	
R205		Not Assigned	
R206	0686-1035	R: fxd, comp, 10 K ohm, 5%, 1/2W	
R207	2100-0884	R: var, 100 ohm, 20%, 1/2W	
R208	0686-4725	R: fxd, comp, 4700 ohm, 5%, 1/2W	
R209, 210	0686-1035	R: fxd, comp, 10 K ohm, 5%, 1/2W	
R211	0686-3325	R: fxd, comp, 3300 ohm, 5%, 1/2W	
R212	0686-6835	R: fxd, comp, 68 K ohm, 5%, 1/2W	
R213	0686-1045	R: fxd, comp, 100 K ohm, 5%, 1/2W	
R214	0686-1025	R: fxd, comp, 1000 ohm, 5%, 1/2W	
R215, 216	0686-1045	R: fxd, comp, 100 K ohm, 5%, 1/2W	
R217	0692-4725	R: fxd, comp, 4700 ohm, 5%, 2W	
R218	0686-1025	R: fxd, comp, 1000 ohm, 5%, 1/2W	
R219	0686-2245	R: fxd, comp, 220 K ohm, 5%, 1/2W	
R220-222	0686-1035	R: fxd, comp, 10 K ohm, 5%, 1/2W	
R223	0686-2215	R: fxd, comp, 220 ohm, 5%, 1/2W	
R224	0686-4705	R: fxd, comp, 47 ohm, 5%, 1/2W	
R225		Not Assigned	
R226	0686-4725	R: fxd, comp, 4700 ohm, 5%, 1/2W	
R227	0686-6835	R: fxd, comp, 68 K ohm, 5%, 1/2W	
R228	0686-3335	R: fxd, comp, 33 K ohm, 5% 1/2W	
R229	0686-2235	R: fxd, comp, 22 K ohm, 5%, 1/2W	
R230	0686-2245	R: fxd, comp, 220 K ohm, 5%, 1/2W	
R231	0686-1035	R: fxd, comp, 10 K ohm, 5%, 1/2W	
R232	0686-2235	R: fxd, comp, 22 K ohm, 5%, 1/2W	
R233	0689-2235	R: fxd, comp, 22 K ohm, 5%, 1W	
R234	2100-0074	R: var, 1 megohm, 30%, 1/4W	
R235	0815-0035	R: fxd, WW, 10 K ohm, 10%, 10W	
R236	0812-0065	R: fxd, WW, 15 K ohm, 5%, 5W	
R237	0689-5135	R: fxd, comp, 51 K ohm, 5%, 1W	
R238	0686-2225	R: fxd, comp, 2200 ohm, 5%, 1/2W	
R239	0686-4745	R: fxd, comp, 470 K ohm, 5%, 1/2W	
R240	0686-6835	R: fxd, comp, 68 K ohm, 5%, 1/2W	
R241	0686-1525	R: fxd, comp, 1500 ohm, 5%, 1/2W	
R242	0686-1025	R: fxd, comp, 1000 ohm, 5%, 1/2W	

Table 6-1. Reference Designation Index (Cont'd)

Reference Designation	Stock No.	Description	Note
S201	3100-0819	Switch: CRYSTAL SELECTOR MARKER	
V201	1923-0021	Electron Tube: 6AU6	
V202	1923-0055	Electron Tube: 6AK5	
V203	1932-0030	Electron Tube: 12AX7	
V204	1932-0029	Electron Tube: 12AU7	
V205	1932-0004	Electron Tube: 6U8	
W201	00240-60064	Cable Assy - includes P201	
W202	00240-60065	Cable Assy - includes J201	
Y201	0410-0085	Crystal: 2.5 MHz	
AUDIO CHASSIS			
C301	0180-0292	C: fxd, elect, 8 $\mu$ f, 450 VDCW	
C302	0160-0760	C: fxd, paper, 0.1 $\mu$ f, 10%, 400 VDCW	
C303	0180-0292	C: fxd, elect, 8 $\mu$ f, 450 VDCW	
C304,305	0160-0770	C: fxd, mica, 1000 pf, 2%, 500 VDCW	
P301	1251-0010	Connector: 4 contact, male	
R301	0812-0079	R: fxd, WW, 25 K ohm, 5%, 5W	
R302	0689-6835	R: fxd, 68 K ohm, 5%, 1W	
R303	0692-6825	R: fxd, 6800 ohm, 5%, 2W	
R304	2100-0881	R: var, 1 K ohm, 20%, 1/2W	
R305	0686-2245	R: fxd, 220 K ohm, 5%, 1/2W	
R306	0727-0973	R: fxd, carbon film, 160 K ohm, 1%, 1W	
R307	2100-0882	R: var, 5 K ohm, 20%, 1/2W	
R308	0686-2215	R: fxd, 220 ohm, 5%, 1/2W	
R309	0727-0973	R: fxd, carbon film, 160 K ohm, 1%, 1W	
RT301	2140-0001	Lamp: 3W, 120V	
S301A, B, C	3100-0829	Switch: AM	
V301	1932-0029	Electron Tube: 12AU7	
RF UNIT			
AT401	00240-60027	RF Step Attenuator	
C401A, B	0121-0108	C: var, 5-45 pf	
C402	00240-00025	Trimmer: 0-0.7 pf	
C403,404	0160-0854	C: fxd, cer, 22 pf, 2-1/2%, 600 VDCW	
C405	0140-0027	C: fxd, mica, 470 pf, 10%, 500 VDCW	
C406,407	0160-0992	C: fxd, cer, 0.01 $\mu$ f, GMV, 450 VDCW	

Table 6-1. Reference Designation Index (Cont'd)

Reference Designation	Stock No.	Description	Note
C408-410	0160-0459	C: fxd, mica, 250 pf, 10%, 500 VDCW	
C411	0160-0992	C: fxd, cer, 0.01 $\mu$ f, GMV, 450 VDCW	
C412-418	0160-0459	C: fxd, mica, 250 pf, 10%, 500 VDCW	
C419		Not Assigned	
C420-427	0160-0459	C: fxd, mica, 250 pf, 10%, 500 VDCW	
C428		Not Assigned	
C429-436	0160-0459	C: fxd, mica, 250 pf, 10%, 500 VDCW	
C437		Not Assigned	
C438	0160-0459	C: fxd, mica, 250 pf, 10%, 500 VDCW	
C439		Not Assigned	
C440	0160-0992	C: fxd, cer, 0.01 $\mu$ f, GMV, 450 VDCW	
C441, 442	0160-0703	C: fxd, paper, 2 $\mu$ f, 200 VDCW	
C443-448	0160-0459	C: fxd, mica, 250 pf, 10%, 500 VDCW	
CR401-404	1910-0033	Diode: Germanium, 1N279	
F401	2110-0064	Fuse: 1/8A, slo-blo, 125V	
FL401	00240-60031	Filter Assy	
FL402	00240-60032	Filter Assy	
J401-403	1250-0075	Connector: BNC UG 291/U	
J404	00240-20055	Connector: BNC, modified	
L401-405		Not Assigned	
L406, 407	00240-80002	Choke, RF, 250 $\mu$ h	
L408, 409	00240-80012	Coil: Yoke, P/O 00240-60057	
L410-416	5080-1701	Coil, RF: 50 $\mu$ h	
L417		Not Assigned	
L418	00240-80013	Coil, RF: 18 $\mu$ h	
L419-425	5080-1701	Coil, RF: 50 $\mu$ h	
L426		Not Assigned	
L427	00240-80013	Coil, RF: 18 $\mu$ h	
L428-431	00202-80009	Coil, RF: 10 $\mu$ h	
M401	1120-0169	Meter	
P401, 402	1250-0061	Connector: BNC UG 88/U	
R401	0721-0029	R: fxd, carbon film 192.6 ohm, 1%, 1/8W	
R402	0721-0030	R: fxd, carbon film 142.3 ohm, 1%, 1/8W	
R403	0721-0033	R: fxd, carbon film, 96.3 ohm, 1%, 1/8W	
R404	0721-0030	R: fxd, carbon film, 142.3 ohm, 1%, 1/8W	
R405	0721-0033	R: fxd, carbon film, 96.3 ohm, 1%, 1/8W	

Table 6-1. Reference Designation Index (Cont'd)

Reference Designation	Stock No.	Description	Note
R406	0721-0033	R: fxd, carbon film, 142.3 ohm, 1%, 1/8W	
R407	0721-0030	R: fxd, carbon film, 96.3 ohm, 1%, 1/8W	
R408	0721-0030	R: fxd, carbon film, 142.3 ohm, 1%, 1/8W	
R409	0721-0033	R: fxd, carbon film, 96.3 ohm, 1%, 1/8W	
R410	0721-0030	R: fxd, carbon film, 142.3 ohm, 1%, 1/8W	
R411	0721-0033	R: fxd, carbon film, 96.3 ohm, 1%, 1/8W	
R412	0721-0030	R: fxd, carbon film, 142.3 ohm, 1%, 1/8W	
R413	0721-0033	R: fxd, carbon film, 96.3 ohm, 1%, 1/8W	
R414	0721-0030	R: fxd, carbon film, 142.3 ohm, 1%, 1/8W	
R415	0721-0033	R: fxd, carbon film, 96.3 ohm, 1%, 1/8W	
R416	0721-0030	R: fxd, carbon film, 142.3 ohm, 1%, 1/8W	
R417	0721-0033	R: fxd, carbon film, 96.3 ohm, 1%, 1/8W	
R418	0721-0030	R: fxd, carbon film, 142.3 ohm, 1%, 1/8W	
R419	0721-0033	R: fxd, carbon film, 96.3 ohm, 1%, 1/8W	
R420	0721-0030	R: fxd, carbon film, 142.3 ohm, 1%, 1/8W	
R421	0721-0031	R: fxd, carbon film, 65.8 ohm, 1%, 1/8W	
R422-425	0686-1005	R: fxd, comp, 10 ohm, 5%, 1/2W	
R426	0686-1015	R: fxd, comp, 100 ohm, 5%, 1/2W	
R428, 428	0686-2235	R: fxd, comp, 22 K ohm, 5%, 1/2W	
R429	0724-0073	R: fxd, carbon film, 100 ohm, 1%, 1/4W	
R430	0686-2215	R: fxd, comp, 220 ohm, 5%, 1/2W	
R431A	2100-0877	R: var, 175 ohm, 20%	
R431B	2100-0876	R: var, 1000 ohm, 20%	
R432	0686-3305	R: fxd, comp, 33 ohm, 5%, 1/2W	
R433	0686-4715	R: fxd, comp, 470 ohm, 5%, 1/2W	
R434	0689-3315	R: fxd, comp, 330 ohm, 5%, 1W	
R435	0689-1035	R: fxd, comp, 10 K ohm, 5%, 1W	
R436	0692-3325	R: fxd, comp, 3300 ohm, 5%, 2W	
R437	0689-3315	R: fxd, comp, 330 ohm, 5%, 1W	
R438	0689-5125	R: fxd, comp, 5100 ohm, 5%, 1W (Nominal Value)	
R439	0692-3325	R: fxd, comp, 3300 ohm, 5%, 2W	
R440	0686-6815	R: fxd, comp, 680 ohm, 5%, 1/2W	
R441	0689-3315	R: fxd, comp, 330 ohm, 5%, 1W	
R442	0686-1045	R: fxd, comp, 100 K ohm, 5%, 1/2W	
R443	0689-1035	R: fxd, comp, 10 K ohm, 5%, 1W	
R444	0692-3325	R: fxd, comp, 3300 ohm, 5%, 2W	
R445	2100-0878	R: var, 10 K ohm, 20%, 1/10W	
R446	0811-0413	R: fxd, WW, 26 K ohm, 1/2%, 1/4W	
R447	0686-1315	R: fxd, comp, 130 ohm, 5%, 1/2W	
R448, 449		Not Assigned	
R450	0686-2245	R: fxd, comp, 220 K ohm, 5%, 1/2W	
R451	2100-0878	R: var, 10 K ohm, 20%, 1/10W	
R452-454		Not Assigned	
R455	0818-0043	R: fxd, WW, 500 ohm, 5%, 30W	

Table 6-1. Reference Designation Index (Cont'd)

Reference Designation	Stock No.	Description	Note
RT401-403	2140-0048	Lamp: Neon, Type NE-2	
S401	00240-20044	Switch: RF SAMPLE	
S402	3100-0818	Switch: FREQ RANGE	
S403		Switch: Step Atten. P/O AT401, NSR	
T401	00240-80007	Transformer: Range 1	
T402	00240-80008	Transformer: Range 2	
T403	00240-80009	Transformer: Range 3	
T404	00240-80010	Transformer: Range 4	
T405	00240-80011	Transformer: Range 5	
V401	1932-0020	Electron Tube: 6BK7B	
V402,403	1921-0011	Electron Tube: 5718	
W401	00240-60035	Cable Assy: includes P402 and J403	
W402	00240-60014	RF Cable Assy: includes J402 and P401	
SWEEP CHASSIS			
C501	0180-0302	C: fxd, elect, 15 $\mu$ f, 450 VDCW	
C502	0160-0833	C: fxd, mylar, 0.5 $\mu$ f, 20%, 400 VDCW	
C503	0160-0879	C: fxd, mylar, 0.25 $\mu$ f, 20%, 400 VDCW	
C504,505	0160-0870	C: fxd, mica, 0.005 $\mu$ f, 2%, 400 VDCW	
C506	0160-0442	C: fxd, cer, 68 pf, 20%, 500 VDCW	
C507	0160-0874	C: fxd, mylar, 1.0 $\mu$ f, 400 VDCW	
C508	0160-0449	C: fxd, paper, 0.5 $\mu$ f, 400 VDCW	
C509	0160-0833	C: fxd, mylar, 0.5 $\mu$ f, 20%, 400 VDCW	
C510	0160-0451	C: fxd, paper, 0.25 $\mu$ f, 400 VDCW	
C511	0160-0833	C: fxd, mylar, 0.5 $\mu$ f, 20%, 400 VDCW	
C512	0140-0031	C: fxd, mica, 220 pf, 10%, 400 VDCW	
C513,514	0160-0843	C: fxd, oil-filled, 1 $\mu$ f, +20%-10%, 600 VDCW	
CR501	1910-0033	Diode: Germanium 1N279	
J501-503	0360-0425	Post, Binding	
P501	1251-0418	Connector: 10 contact, male	
P502	1251-0010	Connector: 4 contact, male	
R501	0689-1025	R: fxd, comp, 1 K ohm, 5%, 1W	
R502,503	0692-2235	R: fxd, comp, 22 K ohm, 5%, 2W	
R504	0686-3335	R: fxd, comp, 33 K ohm, 5%, 1/2W	
R505	0686-1035	R: fxd, comp, 10 K ohm, 5%, 1/2W	
R506	0686-5645	R: fxd, comp, 560 K ohm, 5%, 1/2W	



Table 6-1. Reference Designation Index (Cont'd)

Reference Designation	Stock No.	Description	Note
R507,508		Not Assigned	
R509	0686-1055	R: fxd, comp, 1 megohm, 5%, 1/2W	
R510	2100-0854	R: var, 25 K ohm, 20%, 1/5W	
R511	2100-0886	R: var, 1 megohm, 20%, 1/10W	
R512	0686-1855	R: fxd, comp, 1.8 megohm, 5%, 1/2W	
R513	0686-3355	R: fxd, comp, 3.3 megohm, 5%, 1/2W	
R514	0686-2745	R: fxd, comp, 270 K ohm, 5%, 1/2W	
R515	0686-6815	R: fxd, comp, 680 ohm, 5%, 1/2W	
R516	0686-6835	R: fxd, comp, 68 K ohm, 5%, 1/2W	
R517	0727-0928	R: fxd, carbon film, 11.5 K ohm, 1%, 1/2W	
R518	0686-8225	R: fxd, comp, 8.2 K ohm, 5%, 1/2W	
R519	0686-1055	R: fxd, comp, 1 megohm, 5%, 1/2W	
R520	0686-3355	R: fxd, comp, 3.3 megohm, 5%, 1/2W	
R521	0686-1055	R: fxd, comp, 1 megohm, 5%, 1/2W	
R522	0686-2435	R: fxd, comp, 24 K ohm, 5%, 1/2W	
R523	0686-6245	R: fxd, comp, 620 K, 5%, 1/2W	
R524	0686-4745	R: fxd, comp, 470 K ohm, 5%, 1/2W	
R525-527	2100-0886	R: var, 1 megohm, 20%, 1/10W	
R528	0686-1045	R: fxd, comp, 100 K ohm, 5%, 1/2W	
R529A, B	2100-0883	R: var, 1 megohm, 20% (2 sections)	
R530	0686-7535	R: fxd, comp, 75 K ohm, 5%, 1/2W	
R531-533	2100-0886	R: var, 1 megohm, 20%, 1/10W	
R534,535	2100-0854	R: var, 25 K ohm, 20%, 1/5W	
R536	3100-0821	R: var, 1 megohm, 1/2W, w/switch S503	
R537,538	2100-0854	R: var, 25 K ohm, 20%, 1/5W	
R539	0686-6835	R: fxd, comp, 68 K ohm, 5%, 1/2W	
R540	2100-0854	R: var, 25 K ohm, 20%, 1/5W	
R541	0686-3325	R: fxd, comp, 3300 ohm, 5%, 1/2W	
R542	0686-2235	R: fxd, comp, 22 K ohm, 5%, 1/2W	
R543	0815-0045	R: fxd, WW, 15 K ohm, 5%, 10W	
R544	0815-0048	R: fxd, WW, 1 K ohm, 5%, 10W	
R545	0692-2025	R: fxd, comp, 2 K ohm, 5%, 2W	
R546	0689-1045	R: fxd, comp, 100 K ohm, 5%, 1W	
R547	0815-0043	R: fxd, WW, 10.4 K ohm, 5%, 10W	
R548	0727-0935	R: fxd, carbon film, 110 K ohm, 1%, 1/2W	
R549	2100-0878	R: var, 10 K ohm, 20%, 1/10W	
R550	0812-0079	R: fxd, WW, 25 K ohm, 5%, 5W	
R551	0686-5135	R: fxd, comp, 51 K ohm, 5%, 1/2W	
R552	0727-0903	R: fxd, carbon film, 130 K ohm, 1%, 1/2W	
R553	2100-0854	R: var, 25 K ohm, 20%, 1/5W	

Table 6-1. Reference Designation Index (Cont'd)

Reference Designation	Stock No.	Description	Note
R554	0686-4705	R: fxd, comp, 47 ohm, 5%, 1/2W	
R555	0689-9135	R: fxd, comp, 91 K ohm, 5%, 1W	
R556	0686-3325	R: fxd, comp, 3.3 K ohm, 5%, 1/2W	
R557	0727-0904	R: fxd, carbon film, 140 K ohm, 1%, 1/2W	
R558	2100-0878	R: var, 10 K ohm, 20%, 1/10W	
R559	0689-1045	R: fxd, comp, 100 K ohm, 5%, 1W	
R560	2100-0854	R: var, 25 K ohm, 20%, 1/5W	
R561	0686-2245	R: fxd, comp, 220 K ohm, 5%, 1/2W	
R562	0686-1355	R: fxd, comp, 1.3 megohm, 5%, 1/2W	
R563	0727-0218	R: fxd, carbon film, 180 K ohm, 1%, 1/2W	
R564	2100-0878	R: var, 10 K ohm, 20%, 1/10W	
R565	0686-3355	R: fxd, comp, 3.3 megohm, 5%, 1/2W	
R566	0686-6245	R: fxd, comp, 620 K ohm, 5%, 1/2W	
R567	0727-0938	R: fxd, carbon film, 300 K ohm, 1%, 1/2W	
R568	0727-0934	R: fxd, carbon film, 60 K ohm, 1%, 1/2W	
R569	0686-5135	R: fxd, comp, 51 K ohm, 5%, 1/2W	
R570	0689-3925	R: fxd, 3900 ohm, 5%, 1W	
R571	0686-3355	R: fxd, comp, 3.3 megohm, 5%, 1/2W	
R572	0686-2235	R: fxd, comp, 22 K ohm, 5%, 1/2W	
R573	2100-0854	R: var, 25 K ohm, 20%, 1/5W	
R574	2100-0886	R: var, 1 megohm, 20%, 1/10W	
R575	0689-1825	R: fxd, comp, 1.8 K ohm, 5%, 1W	
R576	0686-3355	R: fxd, comp, 3.3 megohm, 5%, 1/2W	
R577	0686-6845	R: fxd, comp, 680 K ohm, 5%, 1/2W	
R578	0686-6855	R: fxd, comp, 6.8 megohm, 5%, 1/2W	
R579	0686-1235	R: fxd, comp, 12 K ohm, 5%, 1/2W	
R580	0686-9125	R: fxd, comp, 9100 ohm, 5%, 1/2W	
R581		Not Assigned	
R582	0686-1035	R: fxd, comp, 10 K ohm, 5%, 1/2W	
R583	0686-2235	R: fxd, comp, 22 K ohm, 5%, 1/2W	
S501	3100-0820	Switch: RANGE	
S502	3100-0849	Switch: SWEEP SELECTOR	
S503		Switch: CW SWEEP, P/O R536, NSR	
V501	1932-0045	Electron Tube: 12AT7	
V502	1932-0030	Electron Tube: 12AX7	
V503	1930-0013	Electron Tube: 6AL5	
V504	1932-0029	Electron Tube: 12AU7	
V505	1923-0018	Electron Tube: 6AQ5	
V506	1939-0003	Electron Tube: 6BJ7	
V507, 508	1932-0030	Electron Tube: 12AX7	
V509	1923-0018	Electron Tube: 6AQ5	

Table 6-1. Reference Designation Index (Cont'd)

Reference Designation	Stock No.	Description	Note
<b>POWER SUPPLY</b>			
C601	0180-0289	C: fxd, elect, 40 $\mu$ f, 500 VDCW	
C602	0180-0311	C: fxd, elect, 20 $\mu$ f, 600 VDCW	
C603,604	0180-0024	C: fxd, elect, 40 $\mu$ f, 450 VDCW	
C605	0180-0290	C: fxd, elect, 3000 $\mu$ f, 10 VDCW	
CR601	1901-0029	Diode: silicon 3/4 amp, 600 PIV	
CR602A, B, C, D	1882-0012	Rectifier: full-wave bridge	
DS601	2140-0009	Lamp: Type 47	
F601	2110-0003	Fuse: 3 amp, 250 V	
J601	1251-0419	Connector: 10 contact, female	
J602	1251-0408	Connector: 6 contact, female	
J603,604	1251-0011	Connector: 4 contact, female	
J605	1251-0148	Connector: 3 pin, male	
L601	9110-0099	Choke, Filter, 12 hy	
L602	9110-0096	Choke, Filter, 10 hy	
R601	2100-0879	R: var, WW, 3 K ohm, 10%, 4W	
R602	0812-0078	R: fxd, WW, 1500 ohm, 5%, 5W	
R603	0811-0388	R: fxd, WW, 47 K ohm, 1%, 1W	
R604	0811-0930	R: fxd, WW, 20 K ohm, 1%, 3W	
R605,603	0686-4745	R: fxd, comp, 470 K ohm, 5%, 1/2W	
R607	0811-0381	R: fxd, WW, 22 K ohm, 1%, 2W	
R608	2100-0880	R: var, WW, 25 K ohm, 10%, 4W	
R609	0811-0387	R: fxd, WW, 33 K ohm, 1%, 1W	
R610	0811-0385	R: fxd, WW, 6800 ohm, 1%, 1W	
R611	0812-0082	R: fxd, WW, 14 K ohm, 5%, 7W	
R612	0686-4715	R: fxd, comp, 470 ohm, 5%, 1/2W	
R613	0812-0078	R: fxd, WW, 1500 ohm, 5%, 5W	
R614	0690-2211	R: fxd, comp, 220 ohm, 10%, 1W	
R615,616	0812-0081	R: fxd, WW, 3 ohm, 5%, 5W	
R617 - 619	0686-4715	R: fxd, comp, 470 ohm, 5%, 1/2W	
S601	3101-0111	Switch: POWER	
S602	0490-0048	Relay, Thermal: 6N030	
T601	9100-0250	Transformer, Power	
T602	9100-0265	Stabilizer: 60 Hz	
	9100-0301	Stabilizer: 50 Hz	
T603	9100-0253	Transformer, Filament: Single Secondary	
T604	9100-0254	Transformer, Filament: Dual Secondary	

Table 6-1. Reference Designation Index (Cont'd)

Reference Designation	Stock No.	Description	Note
V601		Not Assigned	
V602	1940-0001	Electron Tube: 5651	
V603	1932-0030	Electron Tube: 12AX7	
V604	1932-0018	Electron Tube: 6AS7G	
V605	1930-0008	Electron Tube: 5U4G/GB	
V606	1940-0006	Electron Tube: 0A3	
V607	1932-0018	Electron Tube: 6AS7G	
W601	8120-0078	Power Cable	
	0370-0141	Crank Knob Assy: CENTER FREQ	
	0370-0067	Knob: SWEEP WIDTH	
	0370-0038	Knob: PIP MARKER AMPLITUDE	
	0370-0029	Knob: CRYSTAL MARKER switch, SWEEP RATE, SWEEP SELECTOR, AM	
	0370-0028	Knob: PIP MARKER POSITION (2), CRYSTAL MARKER AMPLITUDE, RF LEVEL VERNIER, TEST SIGNAL AMPLITUDE	
	0370-0024	Knob: CW-SWEEP	
	0403-0048	Glide: bottom cover	
	1200-0002	Socket: 8 pin, (V604, 605, 606, 607, S602)	
	1200-0019	Socket: 9 pin (V603)	
	1200-0028	Socket: 2 pin (Y201)	
	1200-0130	Socket: 7 pin (V602)	
	1200-0132	Socket: 9 pin (V401)	
	1200-0137	Socket: 9 pin (all 9 - pin sockets except for V401 and V603)	
	1200-0139	Socket: 7 pin (V201, 202, 503, 505, 509)	
	1200-0044	Shield, Electron Tube: V602	
	1220-0046	Shield, Electron Tube: V603	
	1400-0084	Fuseholder, Post Type: F601	
	1400-0173	Clamp, Electron Tube: V606	
	1400-0195	Clamp, Electron Tube: S602	
	1400-0196	Clamp, Electron Tube: V604, 605, 607	
	1400-0203	Fuse Mount: F401	
	1400-0006	Steel Ball: 3/32", bearing for frequency dial shaft; detent ball for range switch S402	
	1410-0164	Bearing: Pinion Shaft	
	1430-0142	Gear: phenolic, on R431B	
	1431-0020	Shaft, Pinion	
	1440-0027	Handle, Carrying	
	1450-0099	Pilot Light Socket Assy: red lens	

Table 6-1. Reference Designation Index (Cont'd)

Reference Designation	Stock No.	Description	Note
	1450-0102	Socket: (RT301)	
	1460-0153	Spring: Split gear assy 00240-60025	
	1460-0157	Spring: 1/8" x 5/16 lg. , for 00240-60043	
	1460-0172	Spring: 11/64" dia. x 1" lg. , on S401 shaft	
	1460-0180	Spring, Detent: frequency range shaft	
	1500-0004	Coupling: attenuator shaft	
	1500-0026	Coupling: to S501	
	3100-0808	Detent, Switch: S201	
	5000-3003	Can, Shield: top, S401	
	5020-2222	Gear: bevel, freq range shaft	
	5020-2223	Gear: phenolic, on R431A	
	00202-20071	Bearing thrust: freq dial shaft	
	00225-60003	Panel Bearing Assy: to AT401	
	00232-20025	Spacer: 3/16" dia. x 1-1/8" lg. , threaded	
	00240-00001	Cabinet	
	00240-00014	Shield, Fuse: F601	
	00240-00039	Shield, AT401	
	00240-20009	Spacer: 3/8" O. D. , 1/4" I. D. , 1/8 thk	
	00240-20010	Shaft: freq range switch, bevel gear each end	
	00240-20011	Collar: for 00240-20010 shaft	
	00240-20014	Shaft, Range Switch Drive	
	00240-20016	Collar	
	00240-20017	Shaft, Freq	
	00240-20018	Shaft, Pinion	
	00240-20020	Fiducial: center freq	
	00240-20021	Spacer: 5/16" hex, 1-1/8" lg	
	00240-20023	Spacer: 5/16" hex, 5/16" lg.	
	00240-20022	Shaft, RF Level Vernier	
	00240-20024	Spacer: 1/4" dia. 1-3/16" lg.	
	00240-20025	Shaft: S201, 1-1/4" lg	
	00240-20026	Coupling: for shaft 00240-20025	
	00240-20028	Spacer: tapped, 3/8" x 3/4" x 2-1/2" lg	
	00240-20047	Can, Shield, bottom, for S401	
	00240-20052	Shaft and Detent Assy: for AT401	
	00240-60010	Knob and Dial Assy: Freq Range	
	00240-60008	Shaft, Drive: to S501	
	00240-60011	Knob and Dial Assy: RF level	
	00240-60015	Board, Terminal: M401	
	00240-60016	PC Board, Sweep Chassis, less components	
	00240-60019	PC Board, Audio Oscillator, less components	
	00240-60021	Collar and Grounding Spring: for 1/4" shaft	
	00240-60022	Disc Drive and Gear Assy: freq shaft, 3-1/2" dia. disc	
	00240-60023	Freq Ind. and Arm Assy	
	00240-60024	Gear, Friction	
	00240-60025	Hub and Split Gear Assy	

Table 6-1. Reference Designation Index (Cont'd)

Reference Designation	Stock No.	Description	Note
	00240-60026	Collar and Grounding Spring: for RF vernier shaft	
	00240-60028	Range Switch and Reactor Assy	
	00240-60041	Hub and Dial Assy: Freq., uncalibrated	
	00240-60043	Hub and Split Gear Assy: C401	
	00240-60046	Diode Clip Board	
	00240-60050	Attenuator Switch Rotor Assy	
	00240-60057	Yoke Assy: includes L408 and L409	
	00240-60062	Tie Bar and Arm Assy: to S401	
	00240-60063	Arm and Bushing Assy: on S201	
	00240-60069	Shaft: Flexible with adapters, 3-7/8" lg	
	00240-60072	PC Board: Pip Chassis, less components	
	00240-60073	PC Board: Marker, less components	
	00240-80001	Can, RF Unit Shield	

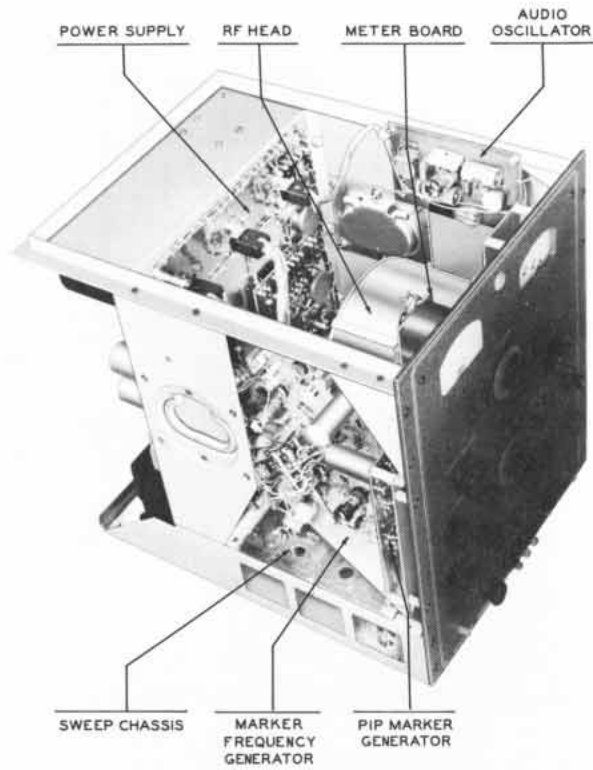

Figure 6-1. Major Subassemblies - 240A

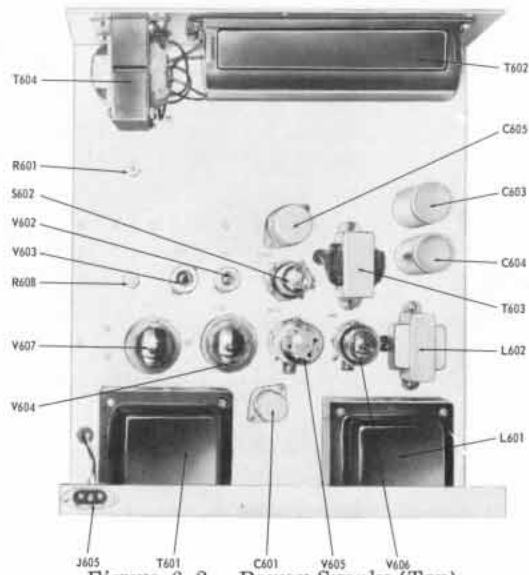

Figure 6-2. Power Supply (Top)

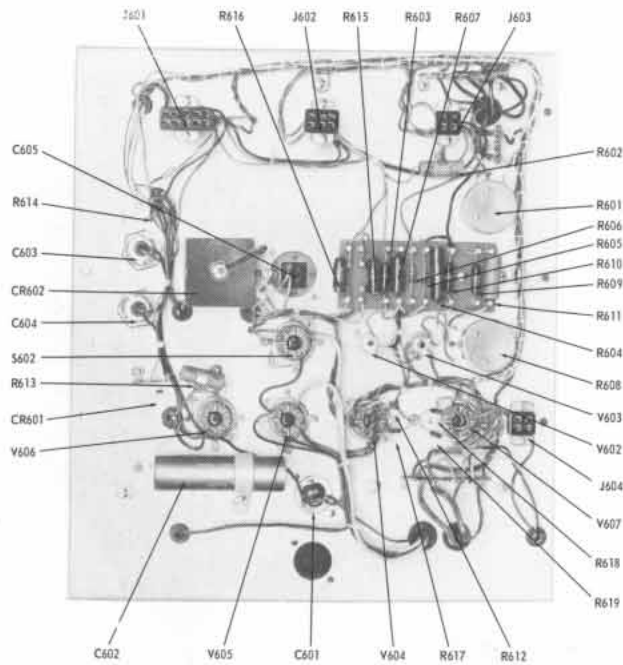

Figure 6-3. Power Supply ( Bottom )

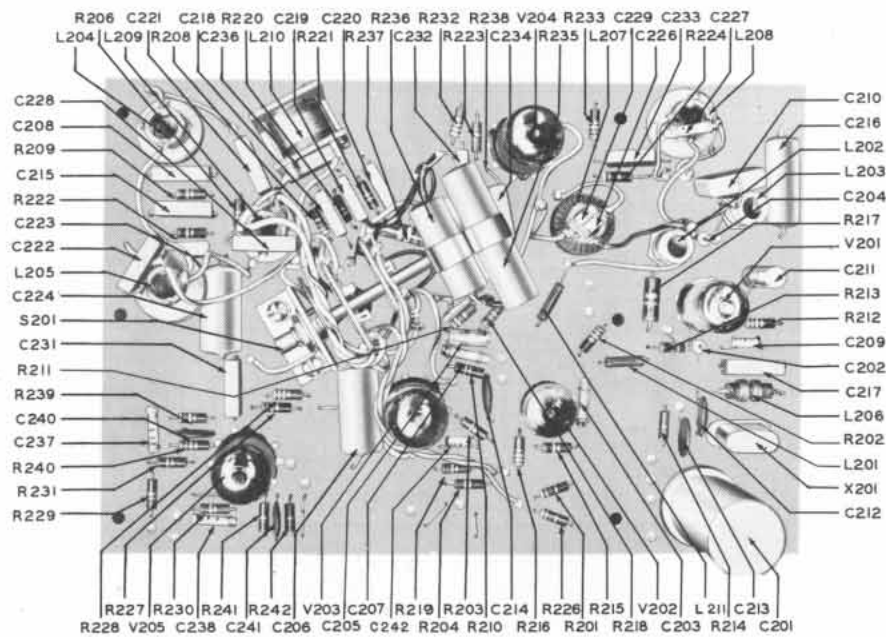

Figure 6-4. Birdie Marker Chassis



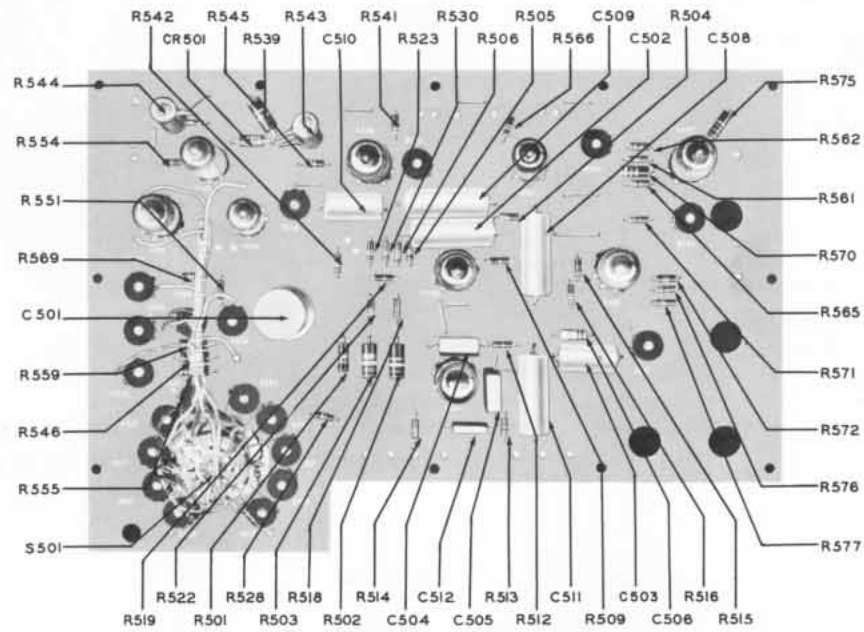

Figure 6-5. Sweep Chassis

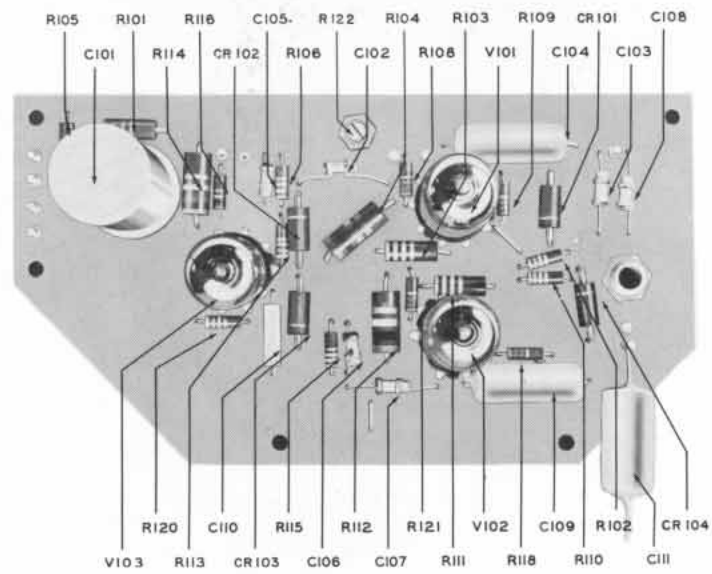

Figure 6-6. Pip Generator Chassis

Section VI  
 Figures 6-7 to 6-9

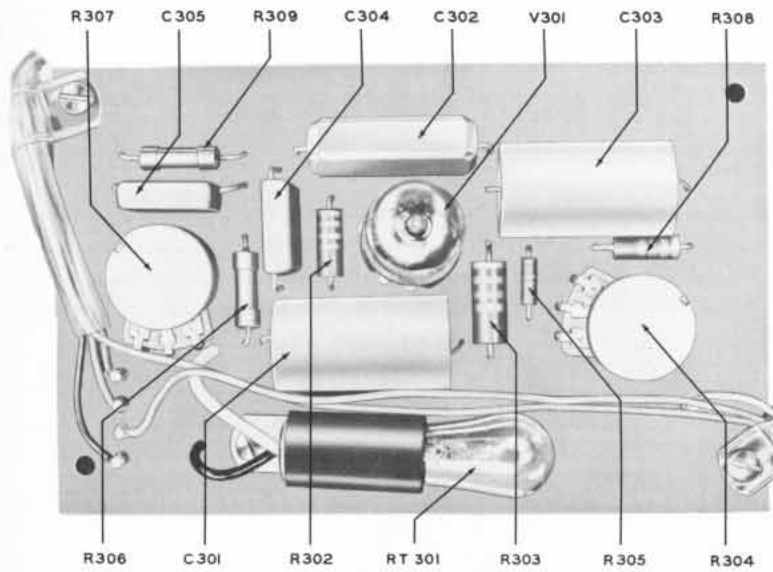

Figure 6-7. Audio Oscillator Chassis

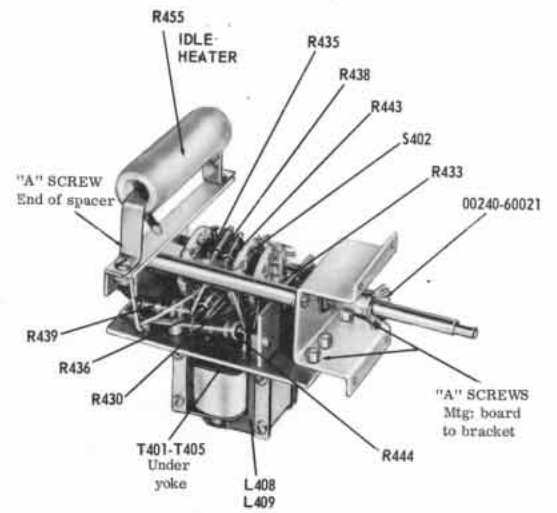

Figure 6-9. Range Switch and Reactor Assembly

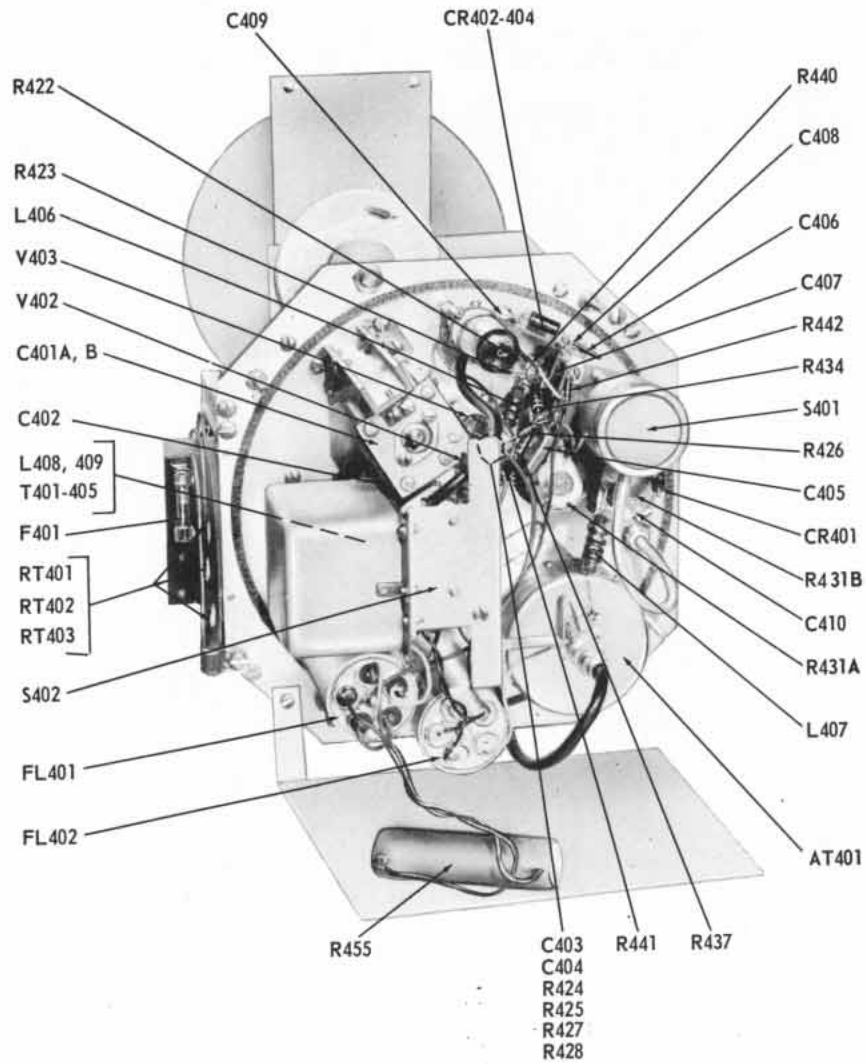







Figure 6-8. RF Unit

## SCHEMATIC DIAGRAMS

### GENERAL NOTES

1. Resistance in ohms, capacitance in picofarads, inductance in microhenries unless otherwise noted.
2. Title inside solid box indicates front panel engraving.
3. VF indicates filtered voltage (see pip chassis schematic).
4. Switches are shown in the counter-clockwise extremes of the front panel controls except for the AM and the CW - SWEEP controls which are shown in their clockwise positions.
5.  indicates screwdriver adjustment.
6.  indicates front panel control.
7. \* indicates factory selected value - average value shown.
8.  indicates test point 3.
9.  indicates RF Unit terminal board pin 10.
10.  indicates assembly board.
11.  indicates wire color code. RMA code is used. Wire color indicated is red-white.

The waveforms shown for the various test points are typical, using an -hp- 175A Oscilloscope with an -hp- 10003 Probe. The sweep time for all waveforms is 5 mc/cm and the sync reference is to TP3 unless otherwise noted. The vertical sensitivity for each waveform was calibrated with the oscilloscope vertical sensitivity setting shown for each test point.

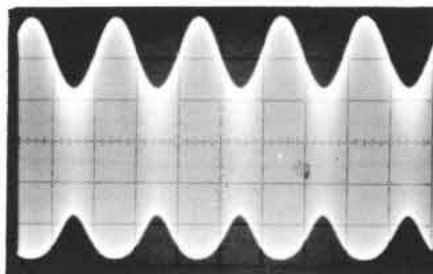

Test Point No. 17  
Location: RF OUTPUT (J402)  
Vertical Sensitivity: not significant  
Remarks: 240A AM output wave form - lower half of waveform is distorted by the metering diodes

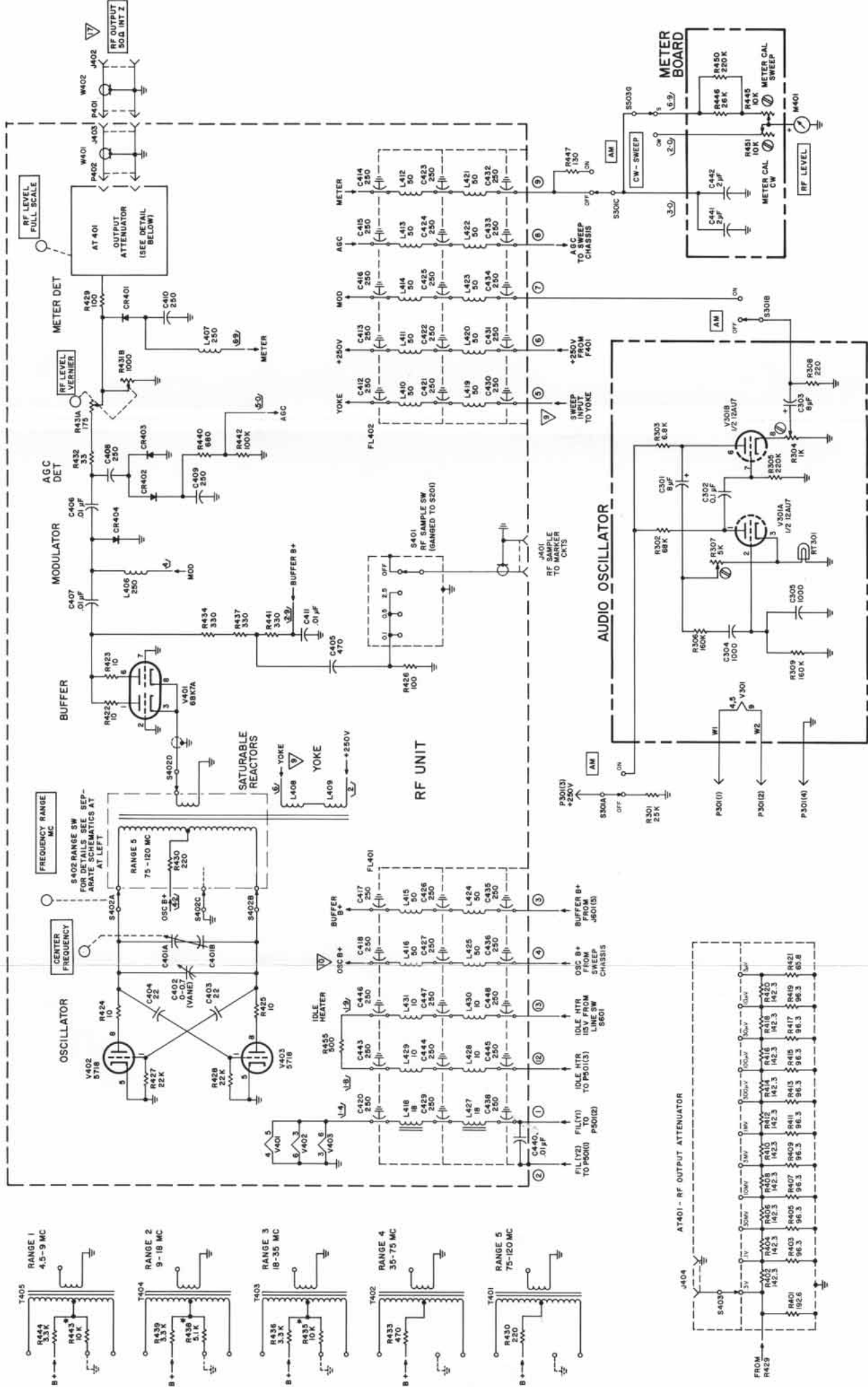

The waveforms shown for the various test points are typical, using an -hp-175A Oscilloscope with an -hp-10003 Probe. The sweep time for all waveforms is 5 ms/cm and the sync reference is to TP3 unless otherwise noted. The vertical sensitivity for each waveform was calibrated with the oscilloscope vertical sensitivity setting shown for each test point.

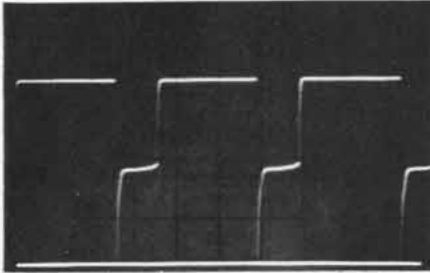

Test Point No. 3  
Location: Pin 6 of V501  
Vertical Sensitivity: 50 v/cm  
Remarks: Zero voltage reference shown at -3cm

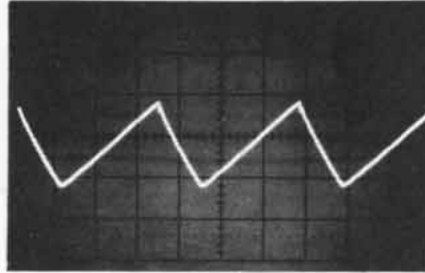

Test Point No. 7  
Location: Front Panel SWEEP OUT  
Vertical Sensitivity: 10 v/cm  
Remarks:

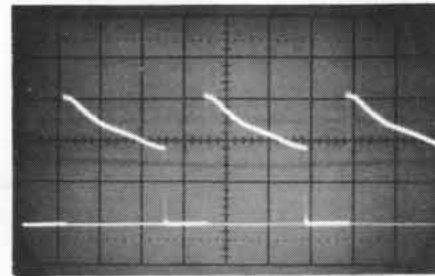

Test Point No. 10  
Location: Pin 2 of V509  
Vertical Sensitivity: 50 v/cm  
Remarks: Voltage variation at this point is 60 v min. to 160 v max. Zero voltage reference shown at -2cm

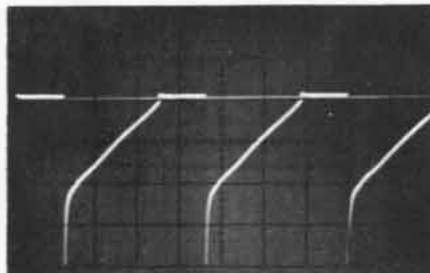

Test Point No. 4  
Location: Pin 7 of V501  
Vertical Sensitivity: 50 v/cm  
Remarks: Zero voltage reference shown at +1cm

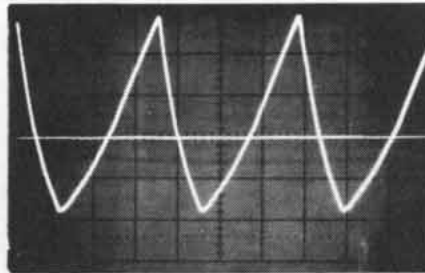

Below 75 Mc

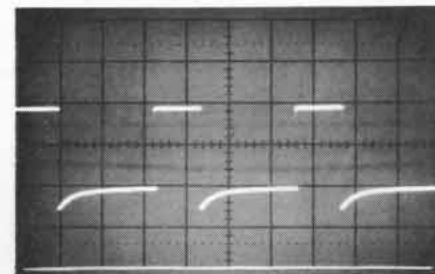

Test Point No. 14  
Location: Pin 1 of V101 or V102  
Vertical Sensitivity: 50 mv/cm  
Remarks: Top of pulse will vary with PIP MARKER POSITION setting. Zero voltage reference shown at -3cm

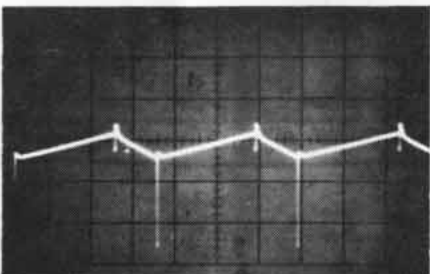

Test Point No. 5  
Location: Junction of C513 and C514  
Vertical Sensitivity: 1 v/cm  
Remarks: Oscilloscope probe ac coupled. Voltage at TP5 is 190 vdc

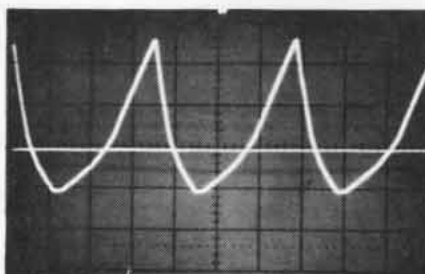

Above 75 Mc

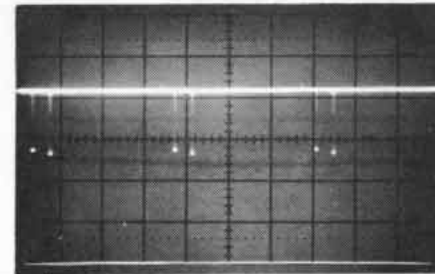

Test Point No. 15  
Location: Pin 1 of V103  
Vertical Sensitivity: 50 v/cm  
Remarks: Zero voltage reference shown at -3cm

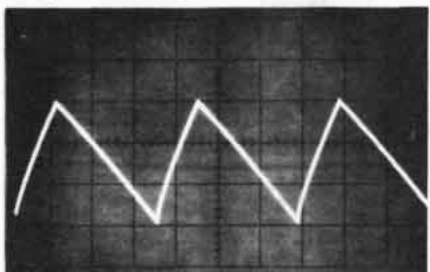

Test Point No. 6  
Location: Pin 1 of V502  
Vertical Sensitivity: 10 v/cm  
Remarks: Oscilloscope probe ac coupled. Voltage at TP6 is 175 vdc

Test Point No. 8  
Location: Pin 1 of V505  
Vertical Sensitivity: 20 v/cm  
Remarks: 240A Sweep width - max.; center frequency - as shown; Zero voltage reference shown at 0cm

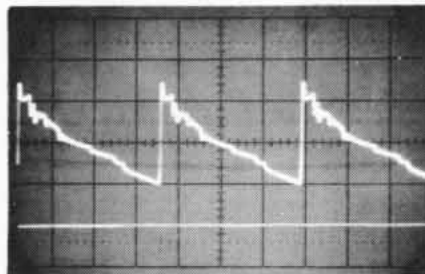

Test Point No. 9 Above 75 Mc

Location: Pin 5 of V505  
Vertical Sensitivity: 100 v/cm  
Remarks: 240A center frequency - above 75 Mc (NOTE: below 75 Mc is similar); zero voltage reference shown at -2cm

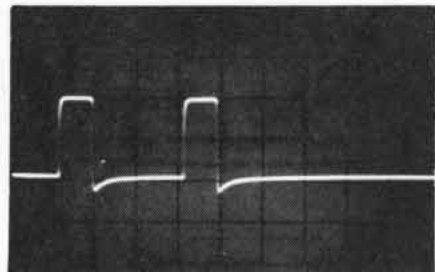

Test Point No. 16  
Location: Pin 6 of V103  
Vertical Sensitivity: 50 v/cm  
Remarks: Oscilloscope sweep time 50  $\mu$ s/cm with internal sync

Section VI  
Sweep and Pip Chassis Schematic

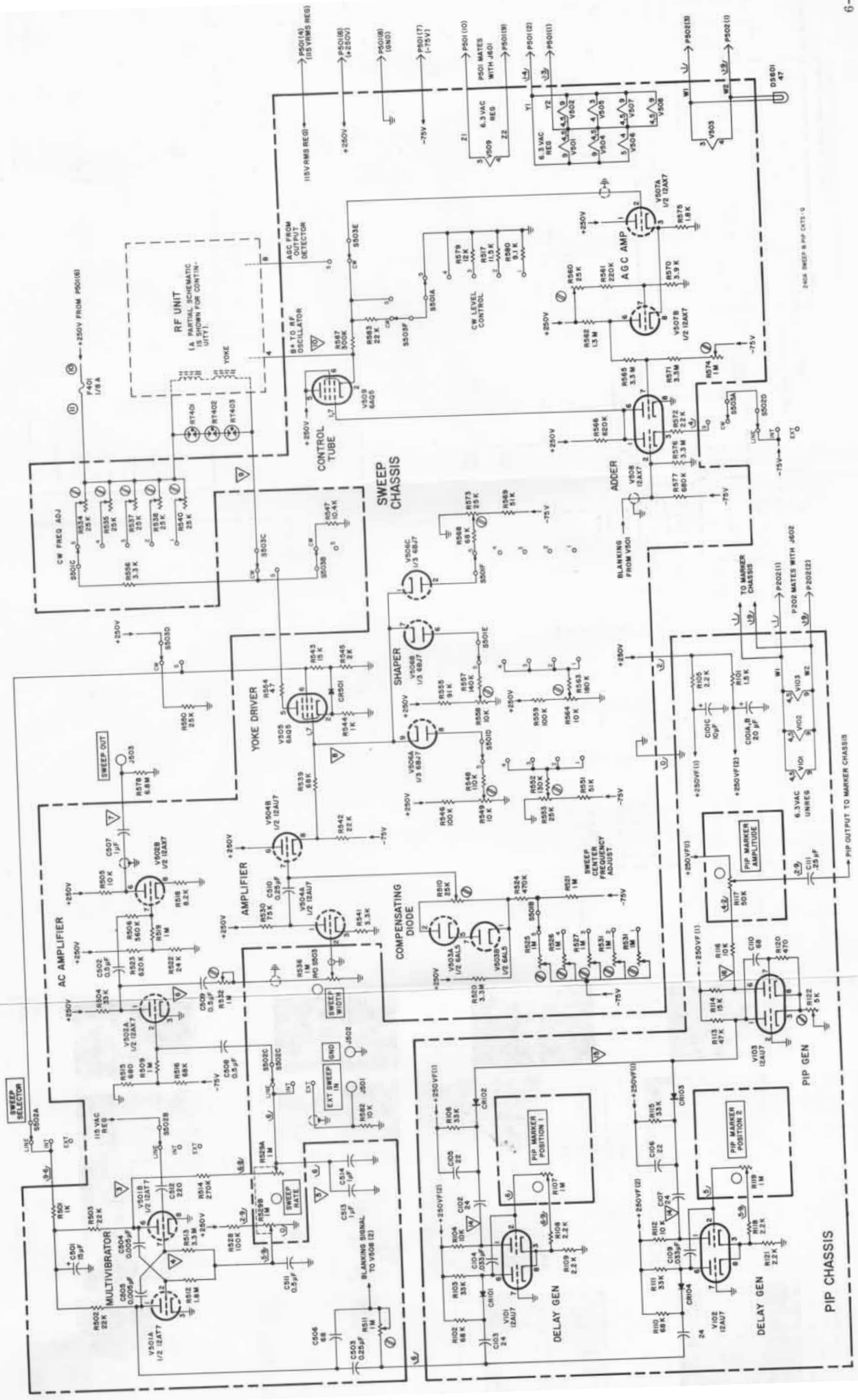

8464 SWEEP & PIP CHASSIS

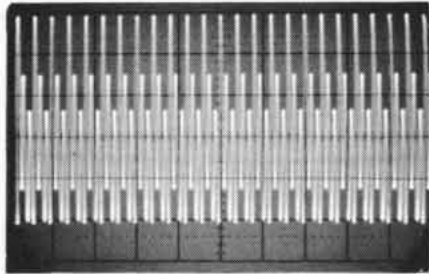

2.5 Mc

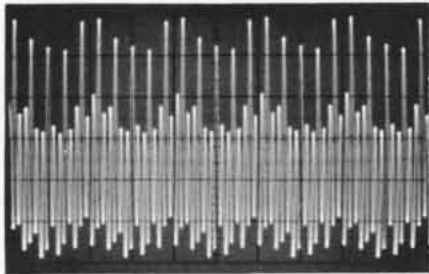

.5 Mc

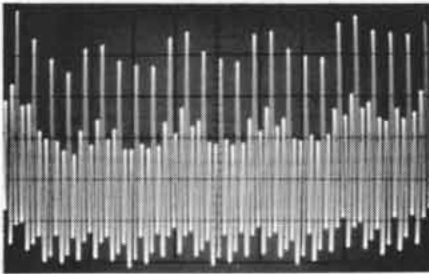

.1 Mc

Test Point No. 11  
 Location: Pin 3 of V203  
 Vertical Sensitivity: 10 v/cm  
 Remarks: 240A MARKER SELECT-  
 OR - as shown. Oscilloscope sweep  
 time - 1  $\mu$ s/cm using internal sync.

The waveforms shown for the various test points are typical, using an -hp- 175A Oscilloscope with an -hp- 10003 Probe. The sweep time for all waveforms is 5 ms/cm and the sync reference is to TP3 unless otherwise noted. The vertical sensitivity for each waveform was calibrated with the oscilloscope vertical sensitivity setting shown for each test point.

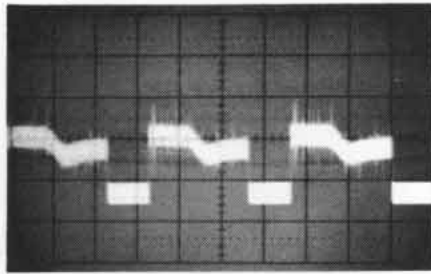

Test Point No. 12  
 Location: Pin 3 of V203  
 Vertical Sensitivity: 10 v/cm  
 Remarks:

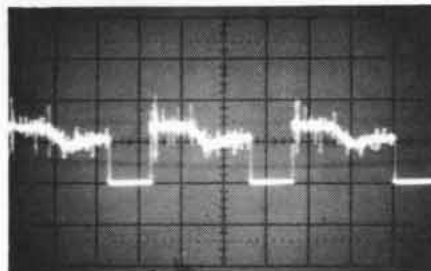

Test Point No. 13  
 Location: Front Panel COMPOSITE  
 OUT  
 Vertical Sensitivity: 5 v/cm  
 Remarks:

Section VI  
Marker Chassis Schematic

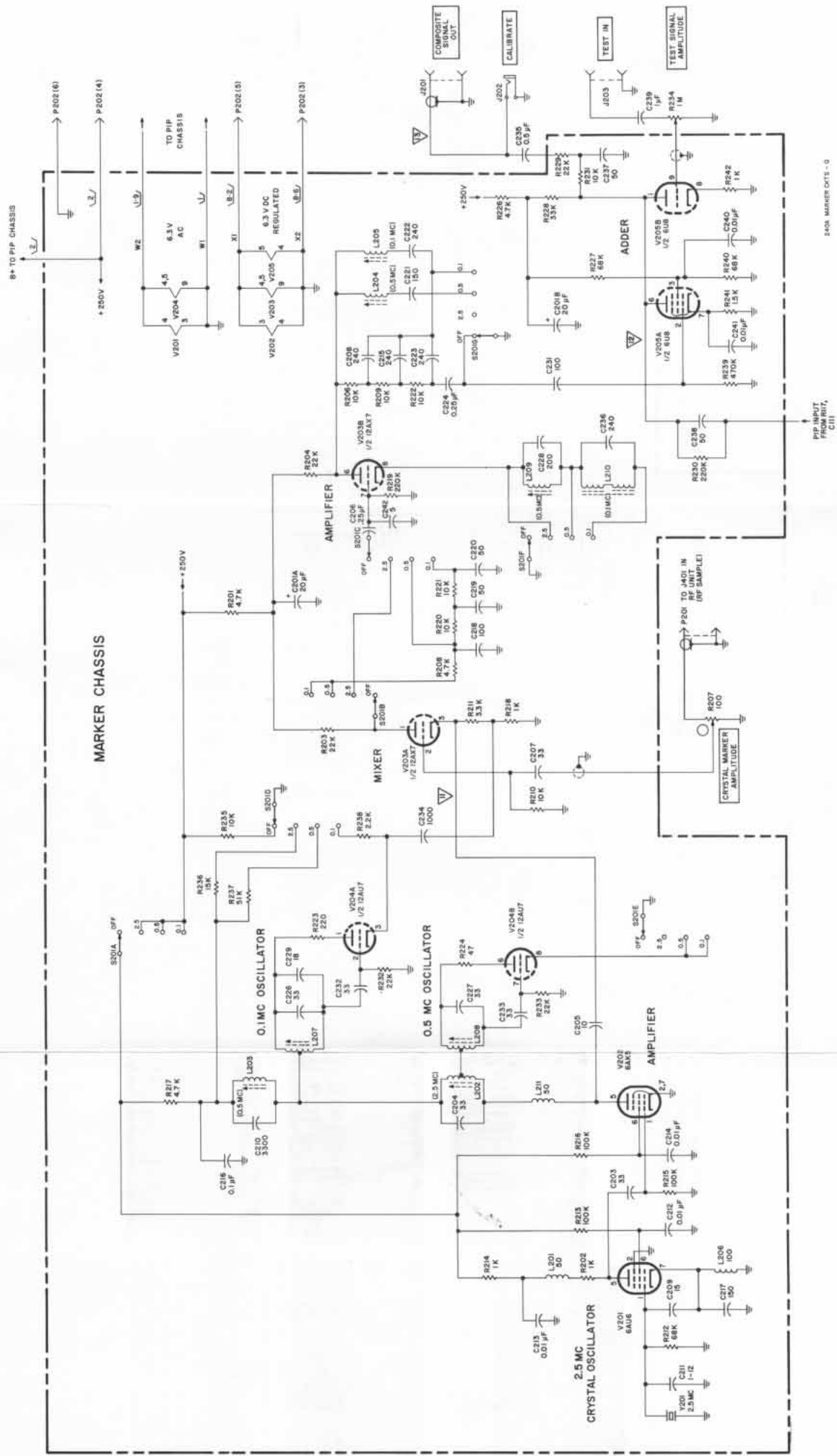

8408 MARKER CRTS - 0



Section VI  
Power Supply Schematic

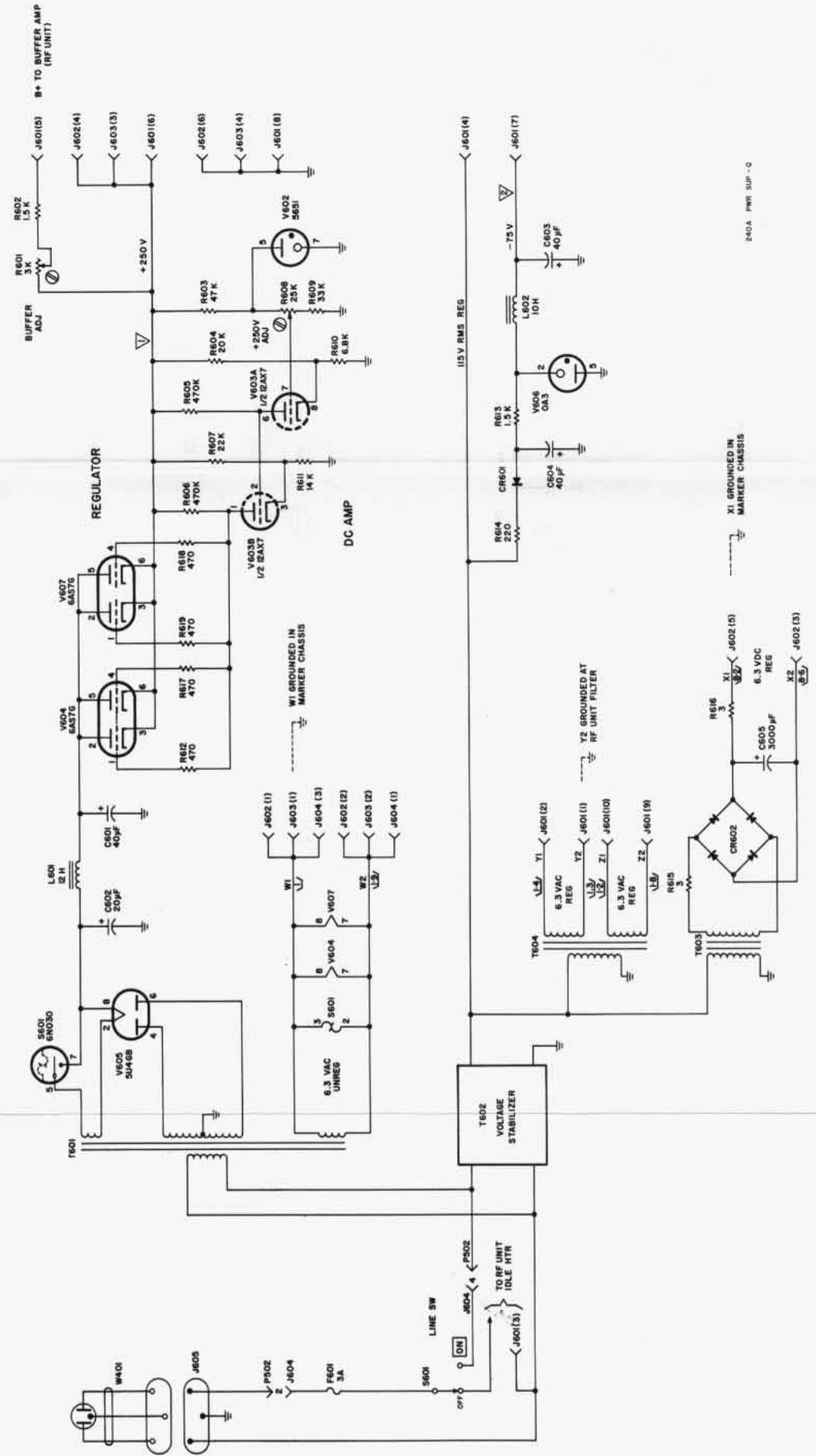

240A PWR SUP - 0

# HEWLETT - PACKARD SALES AND SERVICE OFFICES in the United States and Canada

## ALABAMA

**Huntsville, 35802**  
2003 Byrd Spring Rd. S.W.  
(205) 881-4591  
TWX: 510-579-2204

## ALASKA

**Bellevue, Wash. 98004**  
11656 N.E. 8th Street  
(206) 454-3971  
TWX: 910-443-2303

## ARIZONA

**Scottsdale, 85251**  
3009 No. Scottsdale Rd.  
(602) 945-7601  
TWX: 602-949-0111

**Tucson, 85716**  
232 So. Tucson Blvd.  
(602) 623-2564  
TWX: 602-792-2759

## CALIFORNIA

**North Hollywood, 91604**  
3939 Lankershim Blvd.  
(213) 877-1282 and 766-3811  
TWX: 910-499-2170

**Sacramento, 95821**  
2591 Carlsbad Ave.  
(916) 482-1463  
TWX: 916-444-8683

**San Diego, 92106**  
1055 Shafter Street  
(714) 223-8103  
TWX: 714-276-4263

**Palo Alto, 94303**  
1101 Embarcadero Rd.  
(415) 327-6500  
TWX: 910-373-1280

## COLORADO

**Englewood, 80110**  
7965 East Prentice  
(303) 771-3455  
TWX: 303-771-3056

## CONNECTICUT

**Middletown, 06458**  
589 Saybrook Rd.  
(203) 346-6611  
TWX: 710-428-2036

## FLORIDA

**Miami, 33125**  
2907 Northwest 7th St.  
(305) 635-6461

**Orlando, 32803**  
621 Commonwealth Ave.  
(305) 425-5541  
TWX: 305-275-1234

**St. Petersburg, 33708**  
410-150th Ave., Madeira Beach  
(813) 391-0211  
TWX: 813-391-0666

## GEORGIA

**Atlanta, 30305**  
3110 Maple Drive, N.E.  
(404) 233-1141  
TWX: 810-751-3283

## HAWAII

**North Hollywood, Calif. 91604**  
3939 Lankershim Blvd.  
(213) 877-1282 and 766-3811  
TWX: 910-499-2170

## ILLINOIS

**Skokie, 60078**  
5500 Howard Street  
(312) 677-0400  
TWX: 910-223-3613

## INDIANA

**Indianapolis, 46205**  
3919 Meadows Dr.  
(317) 546-4891  
TWX: 317-635-4300

## LOUISIANA

**New Orleans**  
(504) 522-4359

## MARYLAND

**Baltimore, 21207**  
6660 Security Blvd.  
(301) 944-5400

**Rockville, 20852**  
12303 Twinbrook Pkwy.  
(301) 427-7560  
TWX: 710-828-9684

## MASSACHUSETTS

**Burlington, 01804**  
Middlesex Turnpike  
(617) 272-9000  
TWX: 710-332-0382

## MICHIGAN

**Southfield, 48076**  
24315 Northwestern Hwy.  
(313) 353-9100  
TWX: 313-357-4425

## MINNESOTA

**St. Paul, 55114**  
2459 University Ave.  
(612) 646-7881  
TWX: 910-563-3734

## MISSOURI

**Kansas City, 64131**  
7916 Paseo Street  
(816) 444-9494  
TWX: 816-556-2423

**St. Louis, 63144**  
2814 South Brentwood Blvd.  
(314) 647-4350  
TWX: 314-962-3933

## NEW JERSEY

**Eatontown**  
(201) 542-0852  
**Englewood, 07631**  
391 Grand Avenue  
(201) 567-3933

## NEW MEXICO

**Albuquerque, 87108**  
6501 Lomas Blvd., N.E.  
(505) 255-5586  
TWX: 910-989-1655  
**Las Cruces, 88001**  
114 S. Water Street  
(505) 526-2486  
TWX: 505-524-2671

## NEW YORK

**New York, 10021**  
236 East 75th Street  
(212) 879-2023  
TWX: 710-581-4376  
**Rochester, 14623**  
39 Saginaw Drive  
(716) 473-9500  
TWX: 510-253-5981

**Poughkeepsie, 12601**  
82 Washington Street  
(914) 454-7330  
TWX: 914-452-7425

**Syracuse, 13211**  
5858 East Molloy Rd.  
(315) 454-2486  
TWX: 710-541-0482  
**Endicott, 13764**  
1219 Campville Rd.  
(607) 754-0050  
TWX: 510-252-0890

## NORTH CAROLINA

**High Point, 27262**  
1923 N. Main Street  
(919) 882-6873  
TWX: 510-926-1516

## OHIO

**Cleveland, 44129**  
5579 Pearl Road  
(216) 884-9209  
TWX: 216-888-0715

**Dayton, 45409**  
1250 W. Dorothy Lane  
(513) 298-0351  
TWX: 513-944-0090

## OKLAHOMA

**Oklahoma City**  
(405) 235-7062

## PENNSYLVANIA

**Camp Hill**  
(717) 737-6791  
**West Conshohocken, 19428**  
144 Elizabeth Street  
(215) 248-1600 and 828-6200  
TWX: 215-828-3847

**Monroeville, 15146**  
2545 Moss Side Blvd.  
(412) 271-5227  
TWX: 710-797-3650

## TEXAS

**Dallas, 75209**  
P.O. Box 7166, 3605 Inwood Rd.  
(214) 357-1881 and 332-6667  
TWX: 910-861-4081

**Houston, 77027**  
P.O. Box 22813, 4242 Richmond Ave  
(713) 667-2407  
TWX: 713-571-1353

## UTAH

**Salt Lake City, 84115**  
1482 Major St.  
(801) 486-8166  
TWX: 801-521-2604

## VIRGINIA

**Richmond, 23230**  
2112 Spencer Road  
(703) 282-5451  
TWX: 710-956-0157

## WASHINGTON

**Bellevue, 98004**  
11656 N. E. 8th St.  
(206) 454-3971  
TWX: 910-443-2303

## GOVERNMENT CONTRACTING OFFICES

**Middletown, Pa. 17057**  
Hewlett-Packard  
Contract Marketing Division  
Olmsted Plaza  
(717) 944-7401  
TWX: 717-760-4816

**West Conshohocken, Pa. 19428**  
Hewlett-Packard  
Contract Marketing Division  
144 Elizabeth Street  
(215) 753-1811  
TWX: 215-820-3847

## CANADA

**Montreal, Quebec**  
Hewlett-Packard (Canada) Ltd.  
8270 Mayrand Street  
(514) 735-2273  
TWX: 610-421-3484

**Ottawa, Ontario**  
Hewlett-Packard (Canada) Ltd.  
1762 Carling Avenue  
(613) 722-4223  
TWX: 610-562-1952

**Toronto, Ontario**  
Hewlett-Packard (Canada) Ltd.  
1415 Lawrence Avenue West  
(416) 249-9196  
TWX: 610-492-2382

**Vancouver, B.C.**  
Hewlett-Packard (Canada) Ltd.  
2184 W. Broadway  
(604) 738-7520  
TWX: 610-922-5059

# HEWLETT - PACKARD INTERNATIONAL OFFICES

## Electronic Instrument Sales and Service

### ARGENTINA

Mauricio A. Saurez  
Telecomunicaciones  
Carlos Calvo 224, Buenos Aires  
Tel: 30-6312

### AUSTRALIA

Sample Electronics (Vic.) Pty. Ltd.  
9-11 Cremorne Street  
Richmond E. 1, Victoria  
Tel: 42-4757 (3 lines)  
Sample Electronics (N.S.W.) Pty. Ltd.  
4 Grose Street, Glebe, N.S.W.  
Tel: 69-6338 (6 lines)

### AUSTRIA

UNILABOR H.m.b.H.  
Wissenschaftliche Instrumente  
Rummelhardtgasse 6/3  
P.O. Box 33, Vienna IX/71  
Tel: 42 61 81

### BELGIUM

Hewlett-Packard Benelux  
20-24 Rue de l'Hopital, Brussels 1  
Tel: 11.22.20

### BRAZIL

Ciental Importacao e Comercio Ltda.  
R. Des Eliseu Guilherme, 62  
Sao Paulo 6  
Tel: 32-4332

### CHILE

Hector Calcagni  
Casilla 13942, Santiago  
Tel: 6.42.26

### COLOMBIA

Instrumentacion Henrik A. Langebeck  
& Cia. Ltda.  
Apartado Aereo 6287  
Bogota 1, D.E.  
Tel: 45-78-06  
Cable: AARIS - Bogota

### DENMARK

Tage Olsen A/S  
Ronnegade 1, Copenhagen 0  
Tel: 29.48.00

### FINLAND

INTO O/Y  
P.O. Box 153  
11 Meritullinkatu, Helsinki  
Tel: 6.11.33

### FRANCE

Hewlett-Packard France  
150 Blvd. Massena, Paris 13e  
Tel: 707.97.19

### GERMANY

Hewlett-Packard VgmbH  
Steindamm 35, Hamburg 1  
Tel: 24.05.51

Hewlett-Packard VgmbH  
Kurfurstenstrasse 95  
Frankfurt a. Main  
Tel: 52.00.36

Hewlett-Packard VgmbH  
Reginfriedstrasse 13  
Munich 9  
Tel: 49.51.21/2  
Hewlett-Packard VgmbH  
Technisches Buro  
Herrenbergerstrasse 110  
703 Boblingen, Wurttemberg  
Tel: 6971

Hewlett-Packard VgmbH  
Lietzenburger Strasse 30  
1000 Berlin 30  
Tel: 24 92 71

### GREECE

K. Karayannis  
Klafiomonos Square, Athens 124  
Tel: 230.301

### INDIA

The Scientific Instrument Company, Ld.  
6, Tej Bahadur Sapru Road, Allahabad 1  
Tel: 2451

The Scientific Instrument Company, Ld.  
240, Dr. Dadabhai Naoroji Rd., Bombay 1  
Tel: 26-2642

The Scientific Instrument Company, Ld.  
11, Esplanade East, Calcutta 1  
Tel: 23-4129

The Scientific Instrument Company, Ld.  
30, Mount Road, Madras 2  
Tel: 86339

The Scientific Instrument Company, Ld.  
B-7, Ajmeri Gate Extn., New Delhi 1  
Tel: 271053

### IRAN

Telecom Ltd.  
P.O. Box 1812, Tehran  
Tel: 43850

### ISRAEL

Electronics & Engineering Ltd.  
16 Kremenetski St., Tel Aviv  
Tel: 35021-2-3

### ITALY

Hewlett-Packard Italiana S.p.A.  
Viale Lunigiana 46, Milan  
Tel: 69.15.84/5/6

Hewlett-Packard Italiana S.p.A.  
Palazzo Italia  
Piazza Marconi, 25, Roma-Eur  
Tel: 59.12.544/5

### JAPAN

Yokogawa-Hewlett-Packard Ltd.  
2270 Ishikawa-cho  
Hachioji, Tokyo  
Tel: Hachioji 0426-3-1231 (19 lines)

Yokogawa-Hewlett-Packard Ltd.  
No. 3, 6-chome, Aoyama-Kitamachi  
Akasaka, Minato-ku, Tokyo  
Tel: 403-6511

Yokogawa-Hewlett-Packard Ltd.  
No. 8, Umeda, Kita-ku, Osaka  
Tel: 313-0091

Yokogawa-Hewlett-Packard Ltd.  
No. 4, 3-chome, Himeikedori,  
Chigusa-ku, Nagoya  
Tel: 751-8545

### KOREA

American Trading Company, Korea, Ltd.  
112-35 Sokong-Dong, Jung-ku  
Seoul P.O. Box 1103, Seoul  
Tel: 3-7049, 3-7613

### NETHERLANDS

Hewlett-Packard Benelux N.V.  
23 Burg Roellstraat, Amsterdam W.  
Tel: (020) 13.28.98 and 13.54.99

### NEW ZEALAND

Sample Electronics (N. Z.) Ltd.  
8 Matipo Street  
Onehunga S. E. 5, Auckland  
Tel: 565-361

### NORWAY

Morgenstjerne & Co. A/S  
Ingeniorkfirma  
6 Wessels Gate, Oslo  
Tel: 20 16 35

### PANAMA

Electronico Balboa, S.A.  
P.O. Box 4929  
Panama City 5, Panama  
Tel: 3-0833

### PERU

Fernando Ezeta B.  
Casilla 3061  
Lima  
Tel: 78745

### PORTUGAL

TELECTRA  
Rua Rodrigo da Fonseca 103  
P.O. Box 2531, Lisbon 1  
Tel: 68 60 72 and 68 60 73 and 68 60 74

### PUERTO RICO & VIRGIN ISLANDS

San Juan Electronics, Inc.  
150 Ponce de Leon, Stop 3  
P.O. Box 5167  
Pta. de Tierra Sta., San Juan 00906  
Tel: 725-3342, 724-4406

### SPAIN

ATAIO, Ingenieros  
Enrique Larreta 12, Madrid 6  
Tel: 235.43.44 and 235.43.45

### SOUTH AFRICA

F. H. Fianter & Co. (Pty.), Ltd.  
Rosella House  
Buitencingle Street, Cape Town  
Tel: 3-3817

### SWEDEN

H-P Instrument AB  
Centralvagen 28, Solna, Centrum  
Tel: 83.08.30  
H-P Instrument AB  
Idunagatan 28A  
Goteborg  
Tel: 27 68 00 and 27 68 01

### SWITZERLAND

Max Paul Frey  
Wankdorffeldstrasse 66, Berne  
Tel: (031) 42.00.78

### TAIWAN (FORMOSA)

Hwa Sheng Electronic Co., Ltd.  
21 Nanking West Road, Taipei  
Tel: 4 6076, 4 5936

### TURKEY

TELEKOM Engineering Bureau  
P.O. Box 376—Galata, Istanbul  
Tel: 49.40.40

### UNITED KINGDOM

Hewlett-Packard Ltd.  
Dallas Rd., Bedford, England  
Tel: Bedford 68052

### VENEZUELA

Citec, C. A.  
Edif. Arisan-Of =4  
Avda. Francisco de Miranda-Chacaito  
Apartado del Este 10.837, Caracas  
Tel: 71.88.05

### YUGOSLAVIA

Belram S.A.  
83 Avenue des Mimosas  
Brussels 15, Belgium  
Tel: 35.29.58

For Sales and Service Assistance in Areas Not Listed Contact:

### IN EUROPE

Hewlett-Packard, S. A.  
54 Route des Acacias  
Geneva, Switzerland  
Telephone: (022) 42.81.50  
Telex: 2.24.86  
Cable: HEWPACKSA

### IN LATIN AMERICA

Hewlett-Packard Inter-Americas  
1501 Page Mill Road  
Palo Alto, California 94304, U.S.A.  
Telephone: (415) 326-7000  
TWX: 910-373-1267  
Telex: 033811 Cable: HEWPACK

### ELSEWHERE

Hewlett-Packard  
Overseas Sales Department  
1501 Page Mill Road  
Palo Alto, California 94304, U.S.A.  
Telephone: (415) 326-7000  
TWX: 910-373-1267  
Telex: 033811 Cable: HEWPACK

